



**JICA ASSISTED ODISHA INTEGRATED
SANITATION IMPROVEMENT PROJECT
(ID-P252)**



OFFICE OF THE ENGINEER-IN-CHIEF, OISIP, JICA
Orissa Water Supply & Sewerage Board (OWSSB)
Mahanadi Vihar, Naya Bazar, Cuttack, Odisha PIN 753004
Phone: +91-671-2444511, Fax: +91-671-2441616

DETAILED TENDER CALL NOTICE (DTCN)
FOR
CONSTRUCTION FOR THE HOUSE CONNECTIONS TO THE SEWERAGE
SYSTEM, CUTTACK:
Package (1 to 12)

Package No	Estimated Cost (Rs in Lakh)	Bid Identification No
Package - 1	171.6	Bid Identification No. 01 Dt. 25.04.2022
Package - 2	259.5	
Package - 3	208.1	
Package - 4	208.7	
Package - 5	109.3	
Package - 6	299.2	
Package - 7	139.0	
Package - 8	138.4	
Package - 9	109.5	
Package - 10	115.4	
Package - 11	148.0	
Package - 12	190.4	

**COST OF TENDER PAPER FOR EACH PACKAGE: 10,000/-
(Rupees Ten Thousand only)**

DTCN PART – I: GENERAL & TECHNICAL- BID
(APRIL-2022)

DETAILED TENDER CALL NOTICE (DTCN)

DTCN PART – I: GENERAL & TECHNICAL- BID

Contents

SECTION - 1 NOTICE INVITING TENDER	2
SECTION - 2(A) DETAILS OF THE DOCUMENTS TO BE FURNISHED FOR ONLINE BIDDING	8
SECTION - 2(B) INSTRUCTIONS TO BIDDERS	9
SECTION - 2(C) DATA SHEET	24
SECTION - 2(D) LETTER FOR SUBMISSION OF TENDER	25
SECTION - 3 CONDITIONS OF CONTRACT	26
SECTION - 4 SPECIAL CONDITIONS OF CONTRACT	37
SECTION - 5 SCOPE OF WORK AND TECHNICAL SPECIFICATIONS	51
SCHEDULE – A STRUCTURE & ORGANISATION	59
SCHEDULE – B METHOD STATEMENT	60
SCHEDULE – C INFORMATION REGARDING CURRENT LITIGATION, DEBARRING / EXPELLING OF TENDER OF ABANDONMENT OF WORK BY TENDER ..	61
SCHEDULE – D DECLARATION BY THE TENDERER	62
SCHEDULE – E AFFIDAVIT	63
SCHEDULE – F ANY OTHER INFORMATION, IF ANY	65
SCHEDULE - G FORM OF BID-SECURITY DECLARATION	66

ANNEXURES:

ANNEXURE – I: Guidelines/Procedure to be followed in introduction of e-Procurement in Govt. of Odisha

ANNEXURE – II: Procedure for Electronic Receipt, Accounting and Reporting of Cost of Tender Paper and the agency will submit Bid Security Declaration along with the tender in absence of EMD.

ANNEXURE – III: Drawings

ANNEXURE – IV: Format of Joint Measurement Record (JMR)

**OFFICE OF THE ENGINEER-IN-CHIEF, OISIP, JICA
Orissa Water Supply & Sewerage Board (OWSSB)**
(A Government of Orissa Undertaking)
Mahanadi Vihar, Naya Bazar, Cuttack, Odisha PIN 753004, India
Phone: +91-671-2444511, Fax: +91-671-2441616

INVITATION FOR BIDS (IFB)

NATIONAL COMPETITIVE BIDDING THROUGH e-Procurement

NOTICE INVITING TENDER
Bid Identification No. 1 dtd. 25.04.2022

JICA assisted Orissa Integrated Sanitation Improvement Project in Cuttack implemented by OWSSB invites **Percentage Rate Bids** through **e-Procurement** in conformity with the terms and conditions of the Detailed Tender Call Notice (DTCN) in Two Bid system (Technical Bid and Price Bid) from the bidders of eligible class of contractors registered with the Odisha State Government and Contractors of equivalent grade/class registered with Central Government/ any other State Government/ MES/ Railways having experience in any civil works and fulfilling minimum eligibility criteria as stated hereunder and other detailed qualifying requirements given in the DTCN to be eventually drawn up in the **Standard P-1 Contract Form on percentage rate basis**.

- Bid Submission Criteria:** Bidders may submit bids for one or more than one of the twelve Packages separately. However, one bidder shall be awarded maximum two packages only. But, in case of 'B' class contractors, the total estimated value of 2 packages to be awarded should not exceed Rs. 3.00 crores. For A or above class contractors, the total estimated value of 2 packages to be awarded may or may not exceed Rs. 3.00 crores. Financial bids shall be opened sequentially in decreasing order of the value of estimated cost of packages i.e. the bids shall be opened in order of Package- 6, 2, 4, 3, 12, 1, 11, 7, 8, 10, 9 & 5.

Package No.	Name of the Work	Estimated Value of Work (Rs. Lakh)	Bid Security (EMD) (Rs. Lakh) (Online)	Class of Contractor	Period of Completion	Cost of Bid Document (Online)
1	Construction for The House Connections to the Sewerage System, Cuttack: Zone-1&7A (Bidanasi, Nuasahi, Jyoti Vihar etc. area in Zone-1) and (Duladevi Road, Rajendra Nagar, Tinigharia etc.area in Zone-7A)	171.6	3.4	B and above	11 months	Rs. 10,000/-

JICA Assisted Odisha Integrated Sanitation Improvement Project (ID-P252)
Tender Document for Construction for The House Connections to the Sewerage System, Cuttack

2	Construction for The House Connections to the Sewerage System, Cuttack: Zone-2 (Tulasipur, Kanika Chowk, Siddeshwar Sahi etc. area)	259.5	5.2	B and above	11 months	Rs. 10,000/-
3	Construction for The House Connections to the Sewerage System, Cuttack: Zone-3A (Chandani Chawk, Highcourt, Alisha Bazaar etc. area)	208.1	4.2	B and above	11 months	Rs. 10,000/-
4	Construction for The House Connections to the Sewerage System, Cuttack: Zone-3B (Mata Matha, Chowdhury Bazaar, Ganga Mandir etc. area)	208.7	4.2	B and above	11 months	Rs. 10,000/-
5	Construction for The House Connections to the Sewerage System, Cuttack: Zone-3C (Mission Road, Cantonment Road, Sutahat etc. area)	109.3	2.2	B and above	11 months	Rs. 10,000/-
6	Construction for The House Connections to the Sewerage System, Cuttack: Zone-3D (Seminar Chak, kesharpur, Mangalabagh etc. area)	299.2	6.0	B and above	11 months	Rs. 10,000/-
7	Construction for The House Connections to the Sewerage System, Cuttack: Zone-5A (College Square, Jobra, Majhi Sahi etc. area)	139.0	2.8	B and above	11 months	Rs. 10,000/-
8	Construction for The House Connections to the Sewerage System, Cuttack: Zone-5B (Ranihat, Badambadi, Shankarpur etc. area)	138.4	2.8	B and above	11 months	Rs. 10,000/-
9	Construction for The House Connections to the Sewerage System, Cuttack: Zone-6A (Mahanadi Vihar, BSNL Colony, Gandarpur area)	109.5	2.2	B and above	11 months	Rs. 10,000/-
10	Construction for The House Connections to the Sewerage System, Cuttack: Zone-6B & 6C (Chauliaganj, OMP Square, Aparna Nagar, Niladri Vihar etc. area in Zone-6B) and (Shikharpur, Gurudwara, Old Malgodown road etc. area in Zone-6C)	115.4	2.3	B and above	11 months	Rs. 10,000/-
11	Construction for The House Connections to the Sewerage System, Cuttack: Zone-6D (Cuttack College, Nayabzaar, Gautam Nagar etc. area)	148.0	3.0	B and above	11 months	Rs. 10,000/-

12	Construction for The House Connections to the Sewerage System, Cuttack: Zone-7B (Sartol, Nuapada, Balisahi etc. area)	190.4	3.8	B and above	11 months	Rs. 10,000/-
----	------------------------------------------------------------------------------------------------------------------------------	-------	-----	--------------------	-----------	--------------

2. **Tender Document:** The tender document consists of two parts. DTCN Part-I: General & Technical Bid is common for all Packages. The bidder will fill the Package No., for which he intends to submit the bid, at requisite places. DTCN Part-II: Price Bid / Bill of Quantity (BOQ) is specific for each package.

Bidder shall mark on the cover page/letter of DTCN PART-I the Package No./Zones..... for which bid is submitted.

3. **Mode of Submission of tender:** The bid should be submitted on-line in the website www.tendersodisha.gov.in by eligible bidders. The bidders should have the necessary Portal Enrolment (with his own Digital Signature Certificate). The registered bidders of outside Odisha can also participate in this process, after necessary Portal Enrolment, but shall have to subsequently undergo registration as per prevailing rules with the appropriate authority of the State Government before signing agreement.
4. The bidders desirous to participate in bidding must possess compatible Digital Signature Certificate of Class-II or Class-III and should follow the changes/ modifications/ addendum to DTCN if any.
5. The original documents i.e., Affidavits, Undertakings & Certificates as per the Schedules and Annexure of DTCN that have been uploaded by the bidder in the e-tender website should be submitted for verification during evaluation.
6. **Critical Dates: -**

SN	Description	Critical Dates
1	Period of availability of bid documents online:	From 11:00 AM of 28.04.2022 To 5:00PM of Dt. 19.05.2022
2	Pre-Bid Meeting	12:30 PM on Dt. 09.05.2022 at Office of the Engineer-in-Chief, OISIP, JICA, OWSSB, Mahanadi Vihar, Naya bazar, Cuttack
3	Reply to pre-bid queries	Up to 5:00 PM of Dt. 12.05.2022
4	Last date & time of bid Submission (online)	Up to 5:00 PM of Dt. 19.05.2022
5	Date & time of Opening of Technical Bid	At 12:30 PM of Dt. 20.05.2022

7. **Eligibility Criteria:-The eligible Class of Contractor should be Class B and above(as per the Proceedings of the meeting on revision of the existing provisions under the Rules of Appendix-VIII of the OPWD Code, Volume-II (PWD Contractors Registration Rules-1967) under the Chairmanship of E.I.C (Civil), Odisha held on dt. 26.09.2019).** The firm shall have to submit the performance certificate of the works constructed by them for satisfactory performance from appropriate authority i.e., not below the rank of Executive Engineer /equivalent.

8. The bid for the work shall remain valid for a period of **120 (One Hundred Twenty) days from the date of opening of Price Bid**. If any Bidder/Tenderer withdraws his bid/ tender before the said period or makes any modifications in the terms and conditions of the bid, the said earnest money shall stand forfeited.
9. Bids from Consortium/ Unincorporated Joint Venture is not acceptable.
10. Other details can be seen in the bidding documents, which is available in website www.tendersorissa.gov.in
11. The Bidder should have not been black listed by any Govt./ Govt. Undertaking on the bid opening date. **Self-declaration certificate** by Bidder in the form of Affidavit is to be submitted.
12. All amendments, time extension, clarifications etc. will be uploaded in the website only. Bidders should regularly visit the above website to keep themselves updated.
13. Authority reserves the right to reject any or all the tenders without assigning any reasons thereof.
14. **Name and Address of the Officer Inviting Bids**

OFFICE OF THE ENGINEER-IN-CHIEF, OISIP, JICA
Orissa Water Supply & Sewerage Board (OWSSB)
Mahanadi Vihar, Naya Bazar, Cuttack, Odisha PIN 753004, India
ce_jica@owssb.in

Sd/-
Engineer-in-Chief
OISIP, JICA, OWSSB, Cuttack

CHECK LIST TO BE FILLED UP BY THE BIDDER

Name of the Work: Construction for the House Connections to the Sewerage System, Cuttack: Package:

Sl. No	Particulars	Reference to Clause No.	Whether furnished		Reference to Page No.
			Yes	No	
1.	Cost of tender paper in case of down loading Rs 10,0000 (Online remittance)	DTCN Clause No.			
2.	E.M.D / Bid Security declaration in lieu of Bid Security	DTCN Clause No.			
3.	Copy of valid Registration Certificate	DTCN Clause No.			
4.	Copy of valid GST Registration Certificate	DTCN Clause No.			

5.	Copy of PAN Card	DTCN Clause No.			
6.	Information regarding current litigation, debarring / expelling of the tender or abandonment of the work by the tenderer	DTCN Clause No.			
7.	Structure & Organisation	Schedule - A			
8.	Method Statement	Schedule - B			
9.	Information regarding current litigation/debarment etc.	Schedule - C			
10.	Declaration	Schedule - D			
11.	Affidavits	Schedule - E			
12.	Performance Certificate	Schedule - F			
13.	Other Information	Schedule - F			
14.	Form of Bid-Security Declaration	Schedule - G			

CONTRACT DATA

Sl. No.	Items	Details
A. GENERAL INFORMATIONS		
1.	Bid Identification No.	01 Dt. 25.04.2022
2.	Name of the Work	Construction for The House Connections to the Sewerage System, Cuttack: Package/Zone:
3.	Officer inviting tender	Engineer-in-Chief, OISIP, JICA, OWSSB, Cuttack
4.	Authorized Engineer-in-charge of this work.	Project Engineer, OISIP, JICA (Sewerage), OWSSB, Cuttack
5.	Accepting Authority	Engineer-in-Chief, OISIP, JICA, OWSSB, Cuttack
6.	Amount put to tender	As per Notice Inviting Tender (NIT)
B. BID INFORMATION		
1.	Intended completion period/Time period assigned for Completion	11 Months
2.	Last Date & time of submission of Bid	5:00 PM of Dt. 19.05.2022
3.	Cost of Bid Document (To be Remitted Online)	Rs. 10,000/-

4.	Bid Security	Bid Security declaration in lieu of Bid Security (DTCN, SECTION-2(B): INSTRUCTION TO BIDDERS, Clause 23.1)		
5.	Additional Performance Security			
i)	Amount	Sl. No.	Differential Cost i.e., Estimated Cost put to tender minus the Quoted Amount	Additional Performance Security to be deposited by the Successful bidder
		i	Below 5%	No Additional Performance Security
		ii	From 5% and above and below 10%	50% of (difference between estimated cost put to tender and Bid Amount)
		iii	From 10% and above	150% of (difference between estimated cost put to tender and Bid Amount)
As per amendment Circular No.4559/W, Bhubaneswar dt.05.04.2021 of Govt. of Odisha Works Department.				
ii)	Pledged in favour of	Engineer-in-Chief, OISIP, JICA, OWSSB, Cuttack		
iii)	Payable at	Cuttack, Odisha		
iv)	Type of Instrument	As specified in the Bid document		
6.	Bid validity period	120 days from the date of opening of Price Bid		
7.	Currency of Contract	Indian National Rupee		
8.	Language of Contract	English		
C. Agreement Information				
1.	Execution of agreement	The successful bidder is to execute the agreement with Project Engineer, OISIP, JICA (Sewerage), OWSSB, Cuttack		

SECTION - 2(A) DETAILS OF THE DOCUMENTS TO BE FURNISHED FOR ONLINE BIDDING

- (a) Scanned copies of the following documents to be up-loaded in appropriate place in PDF format in the website www.tendersorissa.gov.in failing which the tender will be cancelled.
- i. Remittance of Cost of Bid Document (Online).
 - ii. GST Registration Certificate.
 - iii. PAN Card.
 - iv. Registration certificate.
 - v. Affidavit / Declaration regarding : Correctness of certificates / no relation certificate/ Acceptance of tender conditions / free from criminal proceedings etc (Schedule-E & D)
 - vi. Letter of submission of tender.
 - vii. Any other relevant required document, if any.
- (b) Scanned Copies of the Certificates / Formats showing details of information to be furnished as per the enclosed formats should be uploaded in appropriate place after converting the same to PDF.
- Schedule - A: Structure & Organisation.
 - Schedule - B: Method Statement
 - Schedule - C: Information regarding current litigation/debarment etc.
 - Schedule - D: Declaration.
 - Schedule - E: Affidavit.
 - Schedule - F: Any other information.
 - Schedule - G: Form of Bid-Security Declaration
- (The details of the Format is enclosed in the DTCN)
- (c) Uploaded documents of valid successful bidders will be verified with the original before acceptance of offer.
- (d) DTCN is not to be uploaded by the bidder. The bidder has to only agree / disagree on the conditions in the DTCN. The bidders, who disagree on the conditions of DTCN, cannot participate in the tender.

SECTION - 2(B) INSTRUCTIONS TO BIDDERS

A. GENERAL

1. Definitions:

- (a) "Employer" means the **Orissa Water Supply & Sewerage Board (OWSSB), Cuttack (A Government of Odisha Undertaking)** represented by the **Engineer-in-Chief, OISIP, JICA, OWSSB, Cuttack** or his authorized representative with whom the selected Contractor signs the contract for the services.
- (b) "Contractor" / Bidder /Tenderer/ Firm / Engineer Firm / Company carry the same meaning throughout the DTCN and Contract.
- (c) "Contract" means the contract / agreement signed by the parties along with all attached documents listed in the DTCN (Tender Document Part-I & II).
- (d) "Data Sheet" means such part of the Instructions to Contractor as are used to reflect assignment conditions and evaluation of the bid.
- (e) "Day" means a calendar day.
- (f) "Government" means the Government of Odisha.
- (g) "Instructions to Bidders (Section-2(B) of DTCN) means the document which provides all information needed to prepare their proposals.
- (h) "TCN" (Section-1 of the DTCN) means the Letter of Invitation being sent by the Employer.
- (i) "Personnel" means professionals and support staff provided by the Contractor and assigned to perform the services in full or in any part thereof.
- (j) "Proposal" means the Technical Proposal and the Financial Proposal (Tender Document).
- (k) "DTCN" means the Detailed Tender Call Notice prepared by the Employer for the selection of contractor.
- (l) "Govt"., means Govt. of Odisha or Govt. of India as the case may be.

2. Introduction / Selection Procedure:

The Employer named in the Data Sheet will select a contract firm to execute the work as described in the scope of work and in the Data sheet.

The Contractor shall bear all costs associated with the execution of the work on **Percentage Bids**. The Employer is not bound to accept any proposal, and reserves the right to annul the

selection process at any time prior to contract award without thereby incurring any liability to the Agency.

3. Location of the Project:

The place of action is at Cuttack Sewerage District I, II and III in the State of Odisha. The details of locations under each package are shown in the drawings (Annexure-III).

4. Source of Funding:

The work will be funded by the **OWSSB**. The Government of India has received a Japanese ODA Loans from Japan International Cooperation Agency (JICA), with the Loan Agreement No. ID-P252, dated 30.03.2016 toward the cost of the project "Odisha Integrated sanitation Improvement Project (OISIP)". The Executing Agency, OWSSB intends to apply a portion of the proceeds of the Loan to eligible payments under the Contract(s) for which these Bidding Documents are issued.

5. Eligibility:

5.1. A Bidder shall be deemed to have the nationality of India.

5.2. Government-owned enterprises shall be eligible only if they can establish that they are legally and financially autonomous and operate under commercial law.

5.3. The Contractor's Class B and above registered Odisha State PWD or equivalent class of CPWD / Railway / MES / Central or other State Govt. and Reputed Engineering Firms. Proof of registration is to be furnished along with the tender.

6. History of Litigation and Criminal Record:

6.1. If any criminal cases are pending against the Contractor (him / her / partners) at the time of submitting the tender, then the tender shall be summarily rejected. In such a case, the Contractor shall submit an affidavit to the effect that the history of litigation, criminal cases pending against him/her/partners furnished by him/her is true.

6.2. In case it is detected at any stage that the affidavit is false, he will abide by the action taken by the **Engineer-in-Chief, OISIP, JICA, OWSSB, Cuttack** without approaching any court whatsoever for redress. He will however, be given suitable opportunity to offer his explanation before action is taken against him.

7. The Contractor has to furnish a declaration that no near relatives are working in the cadre of an Assistant Engineer / Executive Engineer and above in the Orissa Water Supply Sewerage Board (OWSSB) (A Government of Orissa Undertaking).

8. Other Requirements:

8.1. Even if the bidder meets other criteria, his tender shall be summarily rejected if he is found to have misled or made false representation in the form of any of the statements submitted in proof of the eligibility and qualification requirements.

- 8.2.** The tender shall also be summarily rejected if he has a record of performance such as absconding from work, works not properly completed as per contract, inordinate delays in completion, financial failure.
- 8.3.** In addition to the above, even while executing the work, if it is found that he produced false / fake, certificates in his tender, he will be blacklisted.
- 8.4.** The bidders who have in last 3 financial years applied for / are undergoing Corporate Debt Restructuring (CDR)/Strategic Debt Restructuring (SDR) or facing recovery proceeding from Financial Institutions or those are facing Sickness and under consideration of Board for Industrial & Financial Reconstruction (BIFR) are not eligible for qualification. Self-declaration Certificate by the bidder in the form of affidavit is to be submitted.

9. Original Certificates:

Original documents/certificates shall be produced as and when required to verify the copies of statements and other information furnished along with tender. Failure to produce original documents in time will lead to disqualification.

10. Cost of Tendering:

The bidder shall bear all expenses associated with the preparation and submission of his tender. **Engineer-in-Chief, OISIP, JICA, OWSSB, Cuttack** shall in no case be responsible or liable for reimbursement of such expenses.

11. Site Visit:

The bidder is advised to visit and examine the **site** area and its surroundings and obtain for himself all information that may be necessary for preparing the tender and quoting rates at his cost and responsibility.

B. TENDER DOCUMENTS

12. Tender Documents:

12.1. A set of Tender Documents comprising of the DTCN & BOQ includes the following together with all Addenda thereto, which may be issued in accordance with **Clause 2(B) 13 and Clause 2(B) 14**.

Section	Description
DTCN Part – I: General & Technical- Bid	
Section-1	Notice Inviting Tender
Section-2(A)	Details of the Documents to be Furnished for Online Bidding
Section-2(B)	Instructions to Bidders
Section-2(C)	Data Sheet
Section-2(D)	Letter for Submission of Tender
Section-3	Conditions of Contract
Section-4	Special Conditions of Contract
Section-5	Scope of Work and Technical Specifications
Schedule-A to G	Formats for furnishing Information by the Bidder
Annexure-I	Guidelines/Procedure to be followed in introduction of e-Procurement in Govt. of Odisha
Annexure-II	Procedure for Electronic Receipt, Accounting and Reporting of Cost of Tender Paper and the agency will submit Bid Security Declaration along with the tender in absence of EMD.
DTCN Part – II: Price Bid / Bill of Quantity	

12.2. The Contractor is expected to examine carefully all instructions, terms of reference, tender conditions, forms, appendices to tender, addenda in the tender documents. Failure to comply with the requirements of tender submission will be at the contractor's own risk.

13. Deleted.

14. Amendment of Tender Documents:

14.1. At any time prior to the dead line for submission of tenders, **Engineer-in-Chief, OISIP, JICA, OWSSB, Cuttack** may for any reason, whether at its own initiative or in response to the clarifications requested by the prospective Contractor, modify the tender documents by issuing an Addendum.

14.2. Such addenda will be notifying in the website and will be binding upon them.

14.3. In order to afford prospective Contractor reasonable time to take such addenda into account in preparing their tenders, **Engineer-in-Chief, OISIP, JICA, OWSSB, Cuttack** at his discretion, may extend the dead line for the submission of tenders, if necessary.

C. PREPARATION OF TENDER DOCUMENT

Guidelines for preparation of bids on line mode has been issued by Government in Works Department letter No.1027 dated 24.01.09 and appended at last part of this document. The bidders are required to go through the procedure before preparation of bids.

15. Language of the Documents:

All documents relating to the Tender shall be in the English language.

16. Documents Comprising the Tender:

- (a) Detailed Tender Call Notice (DTCN)
- (b) Bill of Quantities.
- (c) All documents stipulated elsewhere in the DTCN.

17. Sufficiency of Tender:

The Bidder shall be deemed to have satisfied himself before tendering as to the correctness and sufficiency of his tender for the services to be provided and of the prices quoted in the financial bid, which shall cover all his obligations under the contract and all matters and things necessary for the successful accomplishment of the work.

18. Preparation of Proposal:

18.1. The Proposal [see Section-2(B) Clause 1(J)] as well as all related correspondence exchanged by the employer & the Contractor shall be written in the language specified in the Data Sheet.

18.2. In preparing the proposal, the Contractor is expected to examine in detail the documents comprising the DTCN. Material deficiencies in providing the information requested may result in rejection of a proposal.

18.3. Site Inspection by tenderer.

The tenderer shall inspect the site at his own cost and shall satisfy himself with regard to the nature and extent of the work involved, the actual site conditions, existing facilities and shall collect any other information which may be required before submitting the tender. Any further data required during execution of the work / scheme shall be ascertained by the contractor at his own cost.

19. Technical Proposal Format and Content:

The Contractor should have sufficient man power to execute & complete the work within the time schedule. He should have sufficient financial background / machinery and equipment required for execution of the work / free from litigation / have good working record of completion of the works in time. It may be noted that the contractor should satisfy the minimum eligible criteria for award of Contract. The Technical Proposal shall provide the information

indicated in the following paragraphs [clause 2(B) 19.1 to 2(B)19.7] using the attached Standard Forms. A page is considered to be one printed side of A4 or letter size paper.

19.1. The Contractor has to furnish the structure & organisation details in **Schedule - A**.

19.2. Method Statement: A description of the approach, methodology and work plan for performing the assignment in **Schedule - B**

19.3. Copy of GST Registration Certificate.

19.4. Copy of PAN Card.

19.5. Copy of Firm's Registration, Authorised dealership, Manufacturing etc.,

19.6. General Power of Attorney if required in favour of the authorised signatory.

19.7. Other information as required in the **Section – 2 (C) Data Sheet**.

20. Bill of Quantities:

20.1. The Contractor shall quote his rates on prescribed form of the Bill of Quantities (BOQ) already supplied in the Tender.

20.2. The offer shall be including all taxes, free delivery inspection, excluding GST.

20.3. The contractor should make realistic assessment of the exhaustive nature of work and the extent of expert technical and managerial inputs and resources required to carry out the work diligently to complete the supply within the stipulated time and quote their offer accordingly.

20.4. The rate quoted by the firm shall be firm.

21. Tender Validity:

21.1. The proposal must remain valid for **120 (One Hundred Twenty)** days from the date of opening of Bid.

22. Authorisation, Corrections, Erasures etc. in Tender Papers:

22.1. The tender document shall be digitally signed by a person duly authorized to do so. Proof of authorization shall be furnished in the form of a certified copy of Power of Attorney, which shall accompany the tender.

22.2. The completed tender shall be submitted without any alterations, inter-relations or erasures except those which accord with instructions given by the **Engineer-in-Chief, OISIP, JICA, OWSSB, Cuttack**.

22.3. Bidders may submit bids for one or more than one of the following zones separately. However, the one bidder shall be awarded one Zone only

23. Earnest Money Deposit / ISD / SD / Additional Perform Security & GST Registration:

23.1 Earnest Money Deposit:

Bid Security declaration should be submitted in lieu of Bid Security as per Works Department Notification No.5984 dt.27.04.2021 & No.18281 Dt.31.12.2021

23.2 Return of EMD:

The Bank will remit the **Earnest Money Deposit on submission/ cancellation of bids** to respective bidder's accounts as per direction received from TIA through e-procurement system. (as per the Appendix-II of DTCN).

The earnest money given by other **one parties (L2)** except one whose tender is accepted shall also be refunded within 15 (Fifteen) days of the acceptance of the tender (as per the Appendix-II of DTCN).

EMD shall also be returned to the unsuccessful bidders of General & Technical Bid (Part-I of tender documents) after finalisation of its evaluation (as per the Appendix-II of DTCN).

23.1. Initial Security Deposit:

The successful Tenderers, after receipt of formal order shall have to furnish Initial Security Deposit (ISD) equal to **2% (two percent)** of the accepted value of the tender in shape of NSC/Postal Saving Pass Book /Post Office Time Deposit /Kishan Vikash Patra/Deposit Receipt in Schedule Bank duly pledged in favour of the **Engineer-in-Chief, OISIP, JICA, OWSSB, Cuttack** payable at Cuttack within 7(seven) days of receipt of intimation failing which their tender shall be cancelled with the forfeiture of EMD.

23.2. Additional Performance Security:

Sl. No.	Differential Cost i.e., Estimated Cost put to tender minus the Quoted Amount	Additional Performance Security to be deposited by the Successful bidder
I	Below 5%	No Additional Performance Security
ii	From 5% and above and below 10%	50% of (difference between estimated cost put to tender and Bid Amount)
iii	From 10% and above	150% of (difference between estimated cost put to tender and Bid Amount)
As per amendment Circular No.4559/W, Bhubaneswar dt. 05.04.2021 of Govt. of Odisha Works Department.		

On intimation from the tender inviting authority, the Successful bidder shall submit the required amount of Additional Performance Security in shape of NSC/ Postal Saving Pass Book /Post Office Time Deposit /Kishan Vikash Patra /Deposit Receipt in Scheduled Bank duly pledged in favour of **Engineer-in-Chief, OISIP, JICA, OWSSB, Cuttack** Payable at Cuttack before issuance of Letter of Acceptance (LoA).

23.3. GST Registration Certificate / GSTIN:

Tenderers are required to submit attested copies of valid **GST Registration Certificate / GSTIN**.

23.4. Security Deposit

In addition to that **5% of gross value** will be deducted from bill(s) of the contractor toward **Security Deposit (SD)** which will be refunded after the defect liability period subject to payment of final bill.

23.5. The EMD shall be forfeited, if, (a) a contractor withdraws the tender during the validity period of tender or (b) if the firm fail to furnish ISD within due time or (c) the successful tenderer fails to sign the Agreement for whatever reason.

23.6. In consideration of the **Engineer-in-Chief, OISIP, JICA, OWSSB, Cuttack** to investigate and to take into account each tender and in consideration of the work thereby involved, all earnest money deposited by the tenderer will be forfeited in the event of such tenderer either modifying or withdrawing his tender at his instance within the validity period.

24. Signing of Tenders / Bid

All tender documents will be signed digitally with Digital Signature Certificate (DSC). The online bidder shall digitally sign on all statements, documents, certificates, uploaded by him, owing responsibility for their correctness / authenticity as per IT Act'2000. If any of the information furnished by the bidder is found to be false / fabricated / bogus/ Bid security shall stand forfeited and the bidder is liable to be blacklisted.

24.1. If the tender is made by an individual, it shall be signed with his own Digital Signature Certificate (DSC).

24.2. If the tender is made by a corporation / company, it shall be signed by a duly authorized officer who shall produce with his tender satisfactory evidence of his authorization. Such a corporation / company may be required before the contract is executed, to furnish evidence of its corporate existence.

The tender shall contain no alterations or additions, except those to comply with instructions issued by the Tender Inviting Officer, or as necessary to correct errors made by the Tenderer, in which case all such corrections shall be digitally signed.

24.3. No alteration made by the tenderer in the contract form, the conditions of the contract, statements / formats accompanying the tender shall be recognized and in case of any alterations made by the tenderer, the tender will be void.

24.4. All documents furnished by the contractor along with the tender are to be digitally signed by the bidder.

25. DELETED.

D. SUBMISSION OF TENDERS

26. In view of adoption of e-procurement process pursuant to Government of Odisha in Works Department Office Memorandum No. FA-R-3/08-4657/W dated 12.03.2008, 4666/W dated 12.03.2008 & 1027/W Dt.24.01.2009 following changes/ modification/ addendum shall be effected.

26.1. Bid Documents:

Bid documents consisting of DTCN & BOQ shall be provided in the portal. Submission of bids will be through the e-Procurement portal. The bidders shall prepare the documents & up load the scanned document to the portal in appropriate place in PDF format.

26.2. Documents Comprising the Bids:

In case of submission of Bids through the e-Procurement Portal, the bidder can submit the scanned copy of the documents in the designated locations of the DTCN & BOQ. Submission of document shall be effected using Digital Signature Certificate (DSC) of appropriate class and thus shall be in encrypted form.

26.3. Bid Price: (BoQ)

Bill of Quantity in Microsoft Excel format shall be made available to the bidder. The bidder shall download that particular Excel sheet and fill in rates both in figures and word at the appropriate location. The bidder will only fill in the designated cell and activate "less" or "excess" to indicate whether his price offer is how much excess or less than the estimate amount. **The bidder is not supposed to change or modify the format of the excel sheet in any form.**

26.4. Bid Security/EMD:

- (i) The bidder shall submit "Bid security Declaration in lieu of Bid security".

26.5. Submission of Bid:

In case of submission of bids through e-Procurement portal on the bidder shall upload the scanned copy/copies of documents as required as per DTCN. The on line bidder shall have to produce the original documents in support of scanned copies & statements up-loaded in the portal on demand by the employer prior to award of contract-failing which action as per DTCN will be initiated.

In case of submission of Bids through the e-Procurement Portal, the bidder shall only submit single copy of the document. He is required to check the documents uploaded with the requirement asked for in the bid. Only after satisfying that all the documents have been uploaded, he should activate submit button. His bids shall not be considered responsive and action as per relevant clause shall be taken if he does not provide the required documents or provided illegible document. Clarity of the document may be ensured by taking out a sample printing.

Bidder shall mark on the cover page/letter of DTCN PART-I the Package No./Zones..... for which bid is submitted.

26.6. Late Bids:

In case of submission of Bids through the e-Procurement Portal, the system shall reject submission of any bid through portal after closure of the receipt time. For all purpose the portal time displayed in the system shall be the time to be followed by the bidder.

27. Modification & Withdrawal of Bid:

In case of submission of Bids through the e-Procurement Portal, it is allowed to modify the bid. The bidder shall have to log on to the system and resubmit the documents as asked for by the system including the price bid. In doing so, the bids already submitted by the bidder will be removed automatically from the system and the latest bid only will be admitted. But the bidder should avoid modification of bid at the last moment to avoid system failure or malfunction of internet or traffic jam. If the bidder fails to submit his modified bids with in the designated time of receipt, the bids already in the system shall be taken for evaluation.

In case of submission of Bids through the e-Procurement Portal, withdrawal of bid is allowed. The bidder has to click on the “withdraw” button and record the necessary justification for the same in the space provided. In addition to this, he has to write a letter addressed to the Officer inviting the bid and up load the scanned document to portal in respective bid. The system shall not allow any withdrawal after expiry of the closure time of the bid.

28. Bid Opening:

In case of submission of Bids through the e-Procurement Portal, the bidders who participated in the online bidding can witness opening of the bid from any system logging on to the portal away from opening place. The bids can only be opened by the pre-designated officials only after the opening time mentioned in the bid.

29. Award of Work:

In case of submission of Bids through the e-Procurement Portal, the system shall generate the Award of Contract letter and intimate the bidders in his e-mail.

E. TENDER OPENING AND EVALUATION

30. Tender Opening:

30.1. The **Engineer-in-Chief, OISIP, JICA, OWSSB, Cuttack** will open the tenders electronically on the date & time mentioned in the **Section -2 (C) Data Sheet**.

30.2. A) A tender shall be rejected if;

- i) BOQ is not enclosed.
- ii) Cost of tender document has not remitted online on submission of bid.
- iii) Bid security declaration, is not enclosed.
- iv) Proof of eligibility is not enclosed.
- v) PAN is not enclosed.
- vi) Affidavit is not enclosed as in **Schedule - E**.
- vii) Copy of GST Registration is not enclosed.
- viii) If the rate quoted by the bidder is below 15% of the BOQ amount.

B) Tenderer should up load other required documents as stipulated in the Section-2(A) of DTCN.

30.3. The **Engineer-in-Chief, OISIP, JICA, OWSSB, Cuttack** may prepare, for his own record, minutes of the tender opening, including the tender opening summary which shall be posted in the portal.

31. DELETED

32. Determination of Responsiveness:

32.1. Prior to the detailed evaluation of tenders, **Engineer-in-Chief, OISIP, JICA, OWSSB, Cuttack** will determine whether each tender has been submitted in the proper form and whether it is substantially responsive to the requirements of the tender documents.

32.2. Any tender which is not substantially responsive to the requirements of the tender documents as mentioned in 30.2(A) will be rejected by the **Engineer-in-Chief, OISIP, JICA, OWSSB, Cuttack**; such a tender shall not be allowed subsequently to be made responsive by the contractor by correcting or withdrawing the non-conforming deviation(s) or reservation(s).

33. Proposal Evaluation:

33.1. From the time of the proposals are opened to the time, the contract is awarded, the contractor should not contact the client on any matter related to its proposal except any required in Clause-2(B)31.

33.2. Any effort by a bidder to influence the client in any form directly or indirectly during the examination, evaluation, ranking of proposals, and recommendation for award of the contract may result in the rejection of the contractor's proposal.

33.3. Evaluation of the Bid:

33.3.1. The Evaluation Committee shall evaluate the Bids on the basis of their responsiveness to the DTCN.

33.3.2. A Bid shall be rejected at this stage if it does not respond to required aspects of the TCN / DTCN.

33.3.3. The bids determined to be substantially responsive will be checked by the employer for any arithmetic error(s).

33.3.4. The Evaluation Committee will correct any computational errors. When correcting computational errors, in case of discrepancy between a partial amount and the total amount or between words and figures, the amount in words will prevail.

33.3.5. If the bid price increases as a result of these corrections, the amount as stated in the bid will be the bid price and any increase will be treated as rebate. If the bid price decreases, the decreased amount will be treated as bid price.

33.4. Selection of Contractor:

If the rate quoted by the bidder is less than 15% of the tendered amount, then such a bid shall be rejected and the tender shall be finalised basing on merits of rest bids. But if more than one bid is quoted at 14.99% (Decimals up to two numbers will be taken for all practical purposes) less than the estimated cost, the tender accepting authority will finalize the tender through a transparent lottery system, where all bidders/their authorised representatives, the concerned General Manager and DAO will remain present. **(As per Amendments to Appendix-IX, Clause-36 of OPWD Code, Vol-II by inclusion vide Govt. Of Odisha, Works Dept office Memorandum No-12366 Dated 08.11.2013).**

In case of Percentage Rate Contract, the contractor shall write percentage excess or less up to two decimal point only. If he writes the percentage excess or less up to two or more decimal points, the first decimal point shall only be considered without rounding off. **(As per Para No. 3.5.5.(V) of OPWD Code Vol-I).**

(a) An intelligent BOQ in MS Excel format shall be made available to the bidder through e-procurement portal. The bidder shall download that particular excel sheet and fill in the rates both in words and figures for all items at the appropriate location. The bidder is not supposed to change or modify the format of the excel sheet in any form.

(b) In percentage rate contracts the schedule of quantities shall mention estimated rate of each item and amount thereto. The tenderer has to mention percentage excess over/ less than the estimated cost (in figures and words) in the prescribed format appended to the tender document. The tenderer who wish to tender for two or more

work shall submit separate tender for each. Each tender shall have the name and number of the works to which they refer, written on the envelope.

In the percentage rate tenders, only percentage quoted shall be considered. Percentage quoted by the tenderer shall be accurately filled in figures and words, so that there is no discrepancy. If any discrepancy is found in the percentage quoted in words and figures, then the percentage quoted by the tenderer in words shall be taken as correct. If any discrepancy is found in the percentage quoted in percentage excess/less and total rate quoted by the tenderer then percentage will be taken as correct. The percentage rate quoted in the tender without mentioning excess or less and not supported with the corresponding amount will be treated as excess. The tenderer will write percentage excess or less up to two decimal point only. If he writes the percentage excess or less up to three or more decimal point, the first two decimal points shall only be considered without rounding off. Where the tenderer has omitted to quote the Percentage rates either in figures or in words, the Officer opening the tender should record the omission.

- (c) The period of completion is fixed and cannot be altered except in case of exceptional circumstances with the due approval from next higher authority.

34. Negotiations:

Negotiations will be held if required with the lowest valid tenderer. In the event of the L1 tenderer has furnished any condition which grossly affects the tender value / contains such conditions which make the value of the offer indefinite, he may be given an opportunity to withdraw such condition(s) to make the tender definite. Failure to withdraw such condition(s) may lead to rejection of the tender as in consistent / non responsive. In such case the employer may explorer the possibility of considering the next valid tender as L1.

If L1 bidder does not turn up for agreement after finalisation of the tender, then he shall be debarred from participation in bidding for three years and action will be taken to black list the contractor. In case, the L2 bidder ,if fulfils, other required criteria would be called for drawing agreement for execution of work subject to condition that L2 bidder negotiates at par with the rate quoted by the L1 bidder otherwise the tender will be cancelled. **(As per the Government of Odisha, Works Department Office Memorandum No.12366 dated 08.11.2013 on amendment to Para No. 3.5.14, Note-I of OPWD Code Vol-I, by inclusion.)**

F. AWARD OF CONTRACT

35. Award Criteria:

- 35.1. After acceptance of the bid by competent authority, the selected contractor will be intimated about such acceptance.
- 35.2. The contractor is expected to commence the work on the date and at the location specified in the Data Sheet.

36. Right to Accept or Reject any or all Tenders:

Notwithstanding Clause 2(B)35, the **Engineer-in-Chief, OISIP, JICA, OWSSB, Cuttack / Government of Odisha** reserves the right to accept or reject any tender, annul the tendering process, reject all tenders at any time or any stage prior to the award of contract without thereby incurring any liability to the affected bidders.

37. Process to be Confidential:

- 37.1. After the opening of tenders as per Clause 2(B)30 & 2(B)33, information relating to examination, clarification, evaluation and comparison of tenders and recommendations, concerning to the award of contract shall not be disclosed to the contractor or any other persons, officially not concerned with the process, until the award of the contract to the successful contractor has been announced.
- 37.2. Any effort by any contractor to influence the Department officials in scrutiny, clarification, evaluation and comparison of tenders, and in any decisions concerning award of a contract, may result in the rejection of their Tender.

38. Notification of Award & signing of Agreement:

- a) The Employer/ **Engineer-in-charge** shall notify acceptance of the work prior to expiry of the validity period by cable, telex or facsimile or e-mail confirmed by registered letter. This Letter of acceptance will state the sum that the Engineer-in-charge will pay the contractor in consideration of the execution & completion of the works by the contractor as prescribed by the contract & the amount of performance security and additional performance security required to be furnished. The issue of the letter of acceptance shall be treated as closure of the Bid process and commencement of the contract.
- b) The contractor after furnishing the required acceptable performance security and additional performance security, "Letter to Proceed" or "Work Order" shall be issued by the Engineer-in-charge with copy thereof to the procurement Officer-Publisher. The Procurement Officer-Publisher shall up load the summary and declare the process as complete.
- c) In the e-Procurement Portal, the system shall generate the template of award letter and the Officer Inviting the Bid shall mention the amount of Performance Security and additional security required to be furnished in the letter and intimate the bidders in his e-mail ID. The issue of the letter of acceptance shall be treated as closure of the Bid process and commencement of the contract.

- d) The bidder shall within 15 days of issue of letter of acceptance, furnish the Performance security & additional Performance security (if any) in the prescribed form & the work programme & shall sign the agreement in prescribed format, failing which the **Engineer-in-Charge** shall without prejudice to any other right or remedy available in law, be at liberty to forfeit the Bid Security absolutely. The agreement will incorporate all agreements between the officer inviting the bid and the successful bidder.
- e) If **L1 bidder does not turn up for agreement** after finalization of the tender, then he shall be debarred from participation in bidding for three years and action will be taken to blacklist the contractor. In that case, the L2 bidder, if fulfils, other required criteria would be called for drawing agreement for execution of work subject to the condition that L2 bidder negotiates at par with the rate quoted by the L1 bidder otherwise the tender will be cancelled. In case a contractor is black listed, it will be widely published and intimated to all departments of Government and also to Govt. of India agencies working in the state. **(Amendment to Para-3.5.14 Note-I of OPWD Code Vol.-I by inclusion)**
- f) **Following documents shall form part of the agreement**
- i. The notice inviting bid, all the documents including additional conditions, specifications and drawings, if any, forming the bid as issued at the time of invitation of bid and acceptance thereof together with any correspondence & documents leading thereto & required amount of performance security including additional performance security as per sub clause 23.2 hereof.
 - ii. Standard Bid Document P.W.D. Form **P-1**.
 - iii. The letter to proceed with the work shall be issued by **Engineer-in-charge** only after signing of the agreement. The notification of award will constitute the formation of the contract subject only to the furnishing of performance security and additional performance security in accordance with the provisions of the agreement.
 - iv. On acceptance of the composite bids by the competent authority the letter of award will be issued by **the Engineer-in-Charge** of the major component of the work on behalf of the Governor of Odisha.

SECTION - 2(C) DATA SHEET

Ref Cl. No	Conditions	Description
2(B)1.(a)	Name and Address of the Employer	THE ENGINEER-IN-CHIEF, OISIP, JICA Orissa Water Supply & Sewerage Board (OWSSB) Mahanadi Vihar, Naya Bazar, Cuttack, Odisha PIN 753004, India Phone: +91-671-2444511, Fax: +91-671-2441616 ce_jica@owssb.in
2(B) 5. Eligibility	Add new sub-clause 5.4	The “ One Bid Per Bidder per Package (Zone/Group of Zones) ”, which is to ensure fair competition, a firm and any affiliate that directly or indirectly controls, is controlled by, or is under common control with that firm shall not be allowed to submit more than one Bid.
2(B) 5. Eligibility	Add new sub-clause 5.4	The firm shall have to submit at least one performance certificate of the work constructed by them during last Five years for satisfactory performance from appropriate authority i.e., not below the rank of Executive Engineer /equivalent.
2(B)15.	Language	Proposals shall be submitted in the following language: English
2(B) 19.7.	Other information required	(a) Performance Certificate: At least one performance certificate of the work constructed by them during last Five years for satisfactory performance from appropriate authority i.e., not below the rank of Executive Engineer /equivalent. in Schedule - G (b) Other Information, if any
2(B)21.	Bid Validity Period	Offers must remain valid for 120 (One Hundred Twenty) days after the date of opening of Bid
2(B)26.	Two Bid System:	To be submitted Two Bid system (Technical Bid and Price Bid).
2(B)30	Bids Opening	Technical Bid will be opened on following date and time: 12.30 Hrs. of 20.05.2022
2(B)33.4	Method of selection:	The Bidder whose offer has been determined to be the lowest evaluated Bid and is substantially responsive to the Tender Documents, provided further that the Bidder is determined to be eligible and qualified to perform the Contract satisfactorily. (L1).

SECTION - 2(D)
LETTER FOR SUBMISSION OF TENDER
[To be filled in by the Bidder]

Note:- (1) Additional conditions appended to the tender will make the tender liable for rejection.
(2) Non-submission of EMD in proper shape and other required documents as detailed hereinafter shall make the tender liable for rejection.

Ref. No. _____/Dated _____

To **The Engineer-in-Chief, OISIP, JICA,
OWSSB, Cuttack**

Sub: **Tender for the Work – “Construction for The House Connections to the Sewerage System Package-....., Cuttack”.**

Ref: Identification No. 01 Dt. 25.04.2022 published in the website www.tendersorissa.gov.in.

Dear Sir,

With reference to the above, we are to inform you that in response to your above referred TCN, we have downloaded the Detailed Tender Call Notice (DTCN) Part-I & II and that after having thoroughly examined the same, we hereby tender for the work to execute the work within the stipulated time and in conformity with the relevant clauses of the DTCN along with all related statutory rules and regulations for the amounts as quoted in the accompanying BOQ.

- 2) I/We have studied, acquainted and satisfied ourselves with the site and its working conditions for the successful and timely completion of the work.
- 3) I/We are submitting herewith Bar Chart to complete the work in time.
- 4) Our offer is unconditional and is in conformity with the requirements of the DTCN. We understand that any additional condition put by us in the tender shall make our tender liable for rejection.
- 5) I/We understood that you are not bound to assign any reason in case of rejection of our tender.
- 6) I/We agree to keep our offer open for a minimum of **120 (One Hundred Twenty)** days from the date of opening of the Bid. Further extension of validity will be our prerogative.

Should this tender be accepted, we hereby agree to abide by and fulfil all the terms and provisions of this Detailed Tender Call Notice (DTCN).

Thanking you.

Yours faithfully,

Name and Signature
of the authorised signatory
along with seal and address of the firm.

SECTION - 3

CONDITIONS OF CONTRACT

3.1. Decision of the Project Engineer is Final:

The party whose tender is accepted hereinafter called the contractor is to provide everything of every sort and kind (with the exceptions noted in the schedule attached) which may be necessary and requisite for the due and proper execution of the several works included in the contract according to the true intent and meaning of the drawings and specification taken together, which are to be signed by **the Project Engineer, OISIP, JICA (Sewerage), OWSSB, Cuttack**. herein after called **the Project Engineer** and the contractor whether the same may or may not be particularly described in the specification or shown on the drawing provided that the same are reasonably and obviously to be inferred there from and in case of any discrepancy between the drawings and the specifications the Project Engineer is to decide which shall be followed.

3.2. Amendment of Errors during Progress of Work:

The contractor is to set out the whole of the works in conjunction with an officer to be deputed by the Project Engineer and during the progress of the works to amend on the requisition of the Project Engineer any errors which may arise therein and provide all the necessary labour and materials for doing. The contractor is to provide all plant, labour and materials (with the exception noted in Schedule), which may be necessary and requisite for the works. All materials and workmanship are to be the best of their respective kinds. The contractor is to leave the works in all respects clean and perfect at the completion thereof.

3.3. Fair Wage Clause:

The contractor shall not employ for the purpose of this contract any person who is below the age of fourteen years, and shall pay to each labourer, for the work done by such labourer, fair wages. Fair wages means wages whether for time or piecework, prescribed by the State P.W.D. provided that where higher rates have been prescribed under the minimum wages Act, 1948, wages at such higher rates should constitute fair wages.

The Project Engineer shall have the right to enquire into and to decide any complaint alleging that the wages paid by the contractor to any labourer for the work done by such labourer is less than the wages paid for similar work in the neighbourhood.

The Officer-in-charge of the work shall have the right to decide whether any labourer employed by the contractor is below the age of fourteen years and to refuse to allow any labourer whom he decides to be below the age of fourteen years, to be employed by the contractor.

3.4. Approved Drawings & Specification of Site with Contractors Agent:

Complete copies of the drawing and specifications signed by the **Project Engineer** and the same or copies thereof are to be kept with the works in-charge of the contractor's

agent which is to be constantly kept on the ground by the contractor and to whom instructions can be given by the Project Engineer.

3.5. Work not to be sublet:

The work should not be sublet. During execution of work if it is found that the work/ part of the work is sublet, the **Project Engineer** may there upon by notice in writing, rescind the contract and the security deposit of the contractor shall thereupon stand forfeited and be absolutely at the disposal of Government. In addition, the contractors shall not be entitled to recover or be paid for any work thereafter actually performed under the contract.

3.6. Deviation from Approved Drawing and Specifications:

The contractor is not to vary or deviate from the drawings or specifications or execute any extra work of any kind whatsoever unless upon the authority of the **Project Engineer** to be sufficiently shown by any order in writing, by any plan or drawing expressly given and signed by him as an extra or variation or by any subsequent written approval signed by him. In case of daily labour all vouchers for the same are to be delivered to the **Project Engineer** or the Officer-in-Charge at least during the week following that in which the work may have been done and no day work shall be allowed unless authorised by the **Project Engineer** and no such authority shall be given if the work is capable of being measured and being paid for at an agreed rate.

3.7. Rate for Extra Work:

Any authority given by the **Project Engineer** for any alterations or addition in or to the works is not to vitiate contract but all additions omissions or variations made in carrying out the works are to be measured and valued and certified by the Project Engineer and added to or deducted from the amount of the contract as the case may be at rates in accordance with the sanctioned schedule of rates in force at the time when the particular item of work was commenced. In those cases in which rates do not exist, the **Chief Engineer, OISIP, JICA, OWSSB, Cuttack** will fix the rates to be paid and his decision shall be final.

3.8. Extension of Time:

Completion time is fixed. However, if the contractor shall desire an extension of time for completion of the work on the ground of his having been come across with unavoidable hindrance in its execution or any other grounds he shall apply in writing to **Project Engineer** within 30 days of the date of the hindrance on account of which he desires such extension as aforesaid and the authority shall if in his opinion (which shall be final) as reasonable ground be shown thereof authorized such extension of time if any, as may in his opinion, be necessary or proper. The authority shall at the same time inform the contractor whether the authority claims compensation for delay, in case there is any delay in execution due to non-availability of stock materials or land or rise in cost of materials and labour or any reason whatsoever beyond the control of authority, the contractor is bound to execute the work as per the terms and rates in the contract and no monetary claim on such account will be acceptable to the authority but extension of time, proportionate to the delay in execution may be granted by the authority considering the merit of the case. The competent authority reserves the right to take any expert advice of any Committee / Secretary / Legal Advisor while considering the application of the

contractor for extension of time and can impose any condition which shall be binding on the contractor.

3.9. Works & Materials at Site to be Property of Government of Odisha:

All works and materials brought and left at site by the contractor or by his orders for the purpose of forming part of the works are to be considered to be the property of the **Governor of Odisha** and the same are not to be removed or taken away by the contractor or any other person without the specific permission in writing of the **Project Engineer** but the Governor of Odisha will not be liable for any loss or damage which may happen to or in respect of any such work or materials either by the same being lost or stolen or injured by weather or otherwise.

3.10. Supply of Materials:

The contractor shall at his own expense provide all materials required for the work. The materials supplied by the contractor shall conform to relevant latest editions of the specification and codes of practices of the Bureau of Indian Standards or in their absence to other specifications as may be specified by the Engineer-in-charge. The contractor shall furnish necessary certificates in support of the quality of the materials as may be required by the Engineer-in-charge.

The Engineer-in-charge shall have absolute authority to test the quality of materials at any time through any reputed laboratory at the cost of contractor. The contractor shall not be eligible for any claim or compensation either arising out of any delay in the work or due to any corrective measures required to be taken on account of and as a result of testing of materials.

The **Project Engineer** has full power for removal from the premises of all materials which, in his opinion, are not in accordance with the specification and in case of default, the **Project Engineer** is to be at liberty to sell such materials and to employ other persons to remove the same without being answerable or accountable for any loss or damage that may happen or arise to such materials. The **Project Engineer** is also to have full power to require other proper materials to be substituted and in case of default, the **Project Engineer** may cause the same to be supplied and all costs which may attend such removal and substitution are to be borne by the contractor and may be recovered from the sale proceeds of such rejected materials when necessary, the balance, if any, being kept in deposit in the contractor's favour.

3.11. Execution with Defective Workmanship & Improper Materials:

If in the opinion of the Project Engineer any of the works have been executed with improper materials or defective workmanship, the contractor is then required by the Project Engineer forthwith to re-execute the same and to substitute proper materials and workmanship and in case of default of the contractor in so doing within a week, the Project Engineer is to have full power to employ other agency to re-execute the work and the cost thereof shall be borne by the contractor.

3.12. Rectification of Defects within Guarantee Period:

Any defects, shrinkage or other faults which may appear within 12 (twelve) months from the completion of the work arising out of defective or improper materials or workmanship are upon the direction of the Project Engineer to be amended and made good by the contractor at his own cost unless the Project Engineer for reasons to be recorded in writing shall decide that they ought to be paid for and in case of default, the Governor of Odisha may recover from the contractor the cost of making good the works.

3.13. Responsibility of the Contractor during Execution of Work:

From the commencement of the works to the completion of the same they are to be under the contractor's charge. The contractor is to be held responsible for and to make good all injuries, damages and repairs occasioned or rendered necessary to the same by fire or other causes and they are to hold the Governor of Odisha harmless from any claims for injuries to persons or for structural damage to property happening from any neglect, default, want of proper care or misconduct on the part of the contractor or of any one of his employees during the execution of the works.

3.14. Execution of Works in the Site by Other Workmen:

The Project Engineer is to have full powers to send workmen upon the premises to execute fittings and other works not included in the contract for whose operations the contractor is to afford every reasonable facility during ordinary working hours provided that such operations shall be carried on in such a manner as not to impede the progress of the work included in the contract but the contractor is not to be responsible for any damage which may happen to or be occasioned by any such fittings or other works.

3.15. Time Control:

(Vide Works Department Office Memorandum No.24716 dtd.24.12.2005 and No.8310 dtd.17.05.2006)

a) Progress of work and Re-scheduling programme.

- i) The Engineer-in-Charge shall issue the letter of acceptance to the successful contractor. The issue of the letter of acceptance shall be treated as closure of the Bid process and commencement of the contract.
- ii) Within 15 days of issue of the letter of acceptance, the contractor shall submit to the Engineer-in-Charge for approval a Programme showing the general methods, arrangements, and timing for all the activities in the Works along with monthly cash flow forecast.
- iii) To ensure good progress during the execution of the work the contractors shall be bound in all cases in which the time allowed for any work exceeds one month to complete, 1/4th of the whole time allowed under the contract has elapsed, 1/2 of the whole of the work before 1/2 of the whole time allowed under the contract has elapsed, 3/4th of the whole of the work before 3/4th of the whole time allowed under the contract has elapsed.

- iv) If at any time it should appear to the Engineer-in-Charge that the actual process of the work does not conform to the programme to which consent has been given the Contractor shall produce, at the request of the Engineer-in-Charge, a revised programme showing the modifications to such programme necessary to ensure completion of the works within the time for completion. If the contractor does not submit an updated Programme within this period, the Engineer-in-Charge may withhold the amount of 1% of the contract value from the next payment certificate and continue to withhold this amount until the next payment after the date on which the overdue Programme has been submitted.
- v) An update of the Programme shall be a programme showing the actual progress achieved on each activity and the effect of the progress achieved on the timing of the remaining work including any changes to the sequence of the activities.
- vi) The Engineer-in-Charge's approval of the Programme shall not alter the Contractor's obligations. The Contractor may revise the Programme and submit it to the Engineer-in-Charge again at any time. A revised Programme is to show the effect of Variations and Compensation Events.

b) Extension of the Completion Date.

- i) The time allowed for execution of the works as specified in the **Contract data** shall be the essence of the Contract. The execution of the works shall commence from the 15th day or such time period as mentioned in letter of Award after the date on which the Engineer-in-Charge issues written orders to commence the work or from the date of handing over of the site whichever is later. If the Contractor commits default in commencing the execution of the work as aforesaid, Government shall without prejudice to any other right or remedy available in law, be at liberty to forfeit the earnest money & performance guarantee / Security deposit absolutely.
- ii) The Contractor shall submit the Time & Progress Chart for each milestone Quarter wise indicating each month and get it approved by the Department. The Chart shall be prepared in direct relation to the time stated in the Contract documents for completion of items of the works. It shall indicate the forecast of the dates of commencement and completion of various trades of sections of the work and may be amended as necessary by agreement between the Engineer-in-Charge and the Contractor within the limitations of time imposed in the contract documents, and further to ensure good progress during the execution of the work, the contractor shall in all cases in which the time allowed for any work, exceeds one month (save for special jobs for which a separate programme has been agreed upon) complete the work as per milestone given in **Contract data**.
- iii) In case of delay occurred due to any of the reasons mentioned below, the Contractor shall immediately give notice thereof in writing to the Engineer-in-Charge but shall nevertheless use constantly his best endeavours to prevent or make good the delay and shall do all that may be reasonably required to the satisfaction of the Engineer-in-Charge to proceed with the works.
 - (1) Force majeure, or
 - (2) Abnormally bad weather, or

- (3) Serious loss or damage by fire, or
 - (4) Civil commotion, local commotion of workmen, strike or lockout affecting any of the trades employed on the work, or.
 - (5) Delay on the part of other contractors or tradesmen engaged by Engineer-in-Charge in executing work not forming part of the Contract.
 - (6) In case a Variation is issued which makes it impossible for Completion to be achieved by the Intended Completion Date without the Contractor taking steps to accelerate the remaining work and which would cause the Contractor to incur additional cost, or
 - (7) Any other cause, which, in the absolute discretion of the authority mentioned, in **Contract data** is beyond the Contractors control.
- iv) Request for reschedule and extension of time, to be eligible for consideration, shall be made by the Contractor in writing within fourteen (14) days of the happening of the event causing delay. The Contractor may also, if practicable, indicate in such a request the period for which extension is desired.
- v) In any such case a fair and reasonable extension of time for completion of work may be given. Such extension shall be communicated to the Contractor by the Engineer-in-Charge in writing, within 3 months of the date of receipt of such request. Non-application by the contractor for extension of time shall not be a bar for giving a fair and reasonable extension by the Engineer-in-Charge and this shall be binding on the contractor.

c) Compensation for Delay

If the contractor fails to maintain the required progress in terms of clause-2 of P-1 Contract or to complete the work and clear the site on or before the contract or extended date of completion, he shall, without prejudice to any other right or remedy available under the law to the Government on account of such breach, pay as agreed compensation the amount calculated at the rates stipulated below as the **Engineer-in-Chief (whose decision in writing shall be final and binding)** may decide on the amount of tendered value of the work for every completed day / month (as applicable) that the progress remains below that specified in Clause-2 of P-1 Contract or that the work remains incomplete. This will also apply to items or group of items for which a separate period of completion has been specified.

Compensation @ 1.5% per month of for delay of work, delay to be completed on per Day basis. Provided always that the total amount of compensation for delay to be paid under this condition shall not exceed 10% of the Tendered Value of work or to the Tendered Value of the item or group of items of work for which a separate period of completion is originally given. The amount of compensation may be adjusted or set-off against any sum payable to the Contractor under this or any other contract with the Government. In case, the contractor does not achieve a particular milestone mentioned in **Contract data**, or the rescheduled milestone(s) in terms of Clause-2.5, the amount shown against that milestone shall be withheld, to be adjusted against the compensation levied at the final grant of extension of time.

Withholding of this amount on failure to achieve a milestone shall be automatic without any notice to the contractor. However, if the contractor catches up with the progress of work on the subsequent milestone(s), the withheld amount shall be released. In case the contractor fails to make up for the delay in subsequent milestone(s), amount mentioned against each milestone missed subsequently also shall be withheld. However, no interest whatsoever shall be payable on such withheld amount.

d) Bonus for early completion

For availing incentive clause in any project which is completed before the stipulated date of completion, subject to other stipulations it is mandatory on the part of the concerned **Engineer-in-Chief** to report the actual date of completion of the project as soon as possible through fax or e-mail so that the report is received within 7 days of such completion by the concerned Superintending Engineer, Chief Engineer & the Administrative Department. The incentive for timely, completion should be on a graduated scale of one percent to 05 percent of the contract value. Assessment of incentives may be worked out for earlier completion of work in all respect in the following scale.

Before 30 % of contract period = 5 % of Contract Value

Before 20 to 30 % of contract period = 4 % of Contract Value

Before 10 to 20 % of contract period = 3 % of Contract Value

Before 5 to 10 % of contract period = 2 % of Contract Value

Before 5% of contract period = 1 % of Contract Value

(Amendment to Para-3.5.5 (V) of Note-III of OPWD Code Vol.-I by inclusion vide O.M. No.5288 dt.04.05.2016)

e) Management Meetings

- i) Either the Engineer or the Contractor may require the other to attend a management meeting. The business of management meetings shall be to review the plans for remaining work and to deal with matters raised in accordance with the early warning procedure.
- ii) The Engineer shall record the business of management meetings and is to provide copies of his record to those attending the meeting and to the Employer. The responsibility of the parties for actions to be taken to be decided by the Engineer either at the management meeting or after the management meeting and stated in writing to all who attended the meeting.

f) Rescission of Contract:

To rescind the contract (of which rescission notice in writing to the contractor under the hand of the General Manager shall be conclusive evidence), 20% of the value of leftover work will be realized from the contractor as penalty.

(Amendment as per letter No.10639 dt.27.05.2005 of Works Department, Odisha)

3.16. Circumstances for Rescission of Contract:

If the contractor shall become bankrupt or compound with or make any assignment for the benefit of his creditors or shall suspend or delay the performance of his part of the contract (except on account of cause mentioned in **Clause 3.15** or in consequence of not having proper instructions for which the contractor shall have duly applied) the Project Engineer may give to the contractor or his assignee or trustee as the case may be notice requiring the works to be proceeded with and in case of default on the part of the contractor for a period of seven days, it shall be lawful for the Project Engineer to rescind the contract, if necessary, and to enter upon and take possession of the work and to employ any other person to carry on and complete the same and to Authorise him or them to use the plant, materials and property of the contractor upon the works and the costs and the charge incurred in any way in carrying on and completing the said works are to be paid to the **Project Engineer** by the contractor or may be set off by the **Project Engineer** against any money due or to become due to contractor. If the assignee or trustee of the Contractor proceeds with the work, the conditions of this contract shall be binding upon the said assignee or trustee.

3.17. Payment Certificate:

A Certificate of the Project Engineer or an award of the refer hereinafter referred to as the case may be showing the final balance due or payable to the contractor is to be conclusive evidence of the works having been duly completed and that the contractor is entitled to receive payment of the final balance, but without prejudice to the liability of the contractor under the provisions of **Clause-3.11**.

3.18. **The Project Engineer** shall make payment of work in full or part thereof those shall have been certified to the Contractor.

3.19. Price Adjustment: Deleted

3.20. Defects Liability Period:

The defect liability is **12 months** from the date of formal taking over of the work by the Engineer-in-charge.

3.21. Contractor Liable for Damage done & for Imperfection for 6 (six) months after Certificate:

If the contractor or his work people or servants shall break, deface, injure or destroy any part of a building or structure in which they may be working or any building, road, fence, enclosure or grass land cultivated ground continue to the premises on which the work or any part of it is being executed or in any damage shall happen to the work while in progress from any cause whatsoever or any imperfection become apparent in it within six months from the date of the final certificate of its completion shall have been given by the Engineer-in-charge, as aforesaid, the contractor shall make the same good at his own expenses or in default the Engineer-in-charge may cause the same to be made good by other workman and deduct the expenses of which the certificate of the Engineer-in-charge shall be final from any sums that may be then or at any time thereafter may become due to the contractor or from his security or the proceeds of sale thereof or a sufficient portion

thereof and the contractor shall be liable to pay of the expenses not so recovered by the Engineer-in-charge.

3.22. Action where No Specification is mentioned:

In the case of any class or items of works for which there is no such specification as mentioned in file, if such work shall be carried out in accordance with the detailed standard specification of Odisha, as followed by the State PWD/PHD and in the event of there being no specifications born in the said standard specification of Odisha for such items of work, then in such case the said item of work shall be carried out in all respects in accordance with the instructions and requirements of the Engineer-in-charge after obtaining approval from competent authority.

3.23. Payment on Intermediate Certificate to be regarded as Advance and Bill to be submitted Monthly:

A bill shall be submitted by the contractor each month on or before the date fixed by the Engineer-in-charge for all works executed in the previous month and the Engineer-in-charge and/or Assistant Engineer and/or Junior Engineer in immediate charge of the work shall take the requisite measurements for the purpose of having the same verified, and the claims for as admissible adjusted if possible before the expiry of ten days from the presentation of the bill. If the contractor does not submit the bill within the time fixed as aforesaid, the Engineer-in-charge and/or his Engineering subordinates shall measure up the said work in the presence of the contractor, whose counter signature to the measurement list will be sufficient warrant, and the Engineer-in-charge and/or Assistant Engineer and/or his Engineering subordinates shall prepare a bill from such list which shall be binding on the contractor in all respects. Payment shall be made to the contractor in all respects.

The minimum value of any bill submitted by the contractor shall not be less than 5% of the total value of work in the contract agreement. Contractor will submit the bill after completion of all the sewer house connections in one lane (from node to node).

The Engineer-in-charge will deduct @ 5% (five percent) of the value of each running bill prepared and submitted by the contractor, if any, on account of works done, and such sum or sums to be held in deposit as a further security for the due performance of the condition of the contract provided always that the Project Engineer may refuse to make such monthly payments if in his opinion, the progress of the work or the conduct of the contractor is not satisfactory or the contractor has in any other way done or neglect to do anything as to make it appear doubtful to the authority as to whether the works will be completed by the contractor in accordance with his contract, or has failed to comply with any instruction or order of Engineering personnel. All such interim payments from time to time shall be regarded as payments by way of advance against the final payment only and not as payments of work actually done and completed and shall not preclude the requirement of bad, unsound and imperfect or unskillful work to be removed and taken away and for reconstructed or re-erected, or be considered as an admission of the due performance of the contract, of any part thereof in any respect, or accrual of any claim not shall it conclude, determine or affect in any way the powers of Engineer-in-charge and/or

Assistant Engineer and/or the Project Engineer under these condition or any of them as to the final settlement of adjustment of the accounts or otherwise or in any other way vary or affect this contract. The contractor shall submit the final bill within one month of the date for completion of the work failing which the Engineer-in-charge or his authorized representatives in the presence of the contractor shall prepare the final bill. For recording final measurement of the work, the Engineer-in-charge or his authorized shall serve a notice upon the contractor stipulating therein the date fixed for recording such measurement. If the contractor fails to attend the recording of final measurement by the Engineer-in-charge or his authorized representative on the date of stipulated, the Engineer-in-charge may at his discretion get the measurements recorded ex-parte or fix up another date as per his own convenience. Such measurements and the total amount payable to the contractor as certified by the Engineer-in-charge shall be final and binding on all parties.

3.24. Black Listing:

A Contractor may be black listed as per amendment made to **Appendix XXXIV to OPWD Code Vol.-II on rules for black listing of Contractors vide letter No.3365 Dt.01.03.2007 of Works Department, Odisha**. As per said amendment a Contractor may be blacklisted.

- a) Misbehavior/threatening of Departmental & supervisory officers during execution of work/tendering process.
 - b) Involvement in any sort of tender fixing.
 - c) Constant non-achievement of milestones on insufficient and imaginary grounds and non-adherence to quality specifications despite being pointed out.
 - d) Persistent and intentional violation of important conditions of contract.
 - e) Security consideration of the State i.e., any action that jeopardizes the security of the State.
 - f) Submission of false/ fabricated / forged documents for consideration of a tender.
- 3.25. If the rate quoted by the bidder is less than 15% of the tendered amount, then such a bid shall be rejected and the tender shall be finalized basing on merits of rest bids. But if more than one bid is quoted at 14.99% (Decimals up to two numbers will be taken for all practical purposes) less than the estimated cost, the tender accepting authority will finalize the tender through a transparent lottery system, where all bidders / their authorized representatives, the concerned General Manager and DAO will remain present.

(As included in **Appendix – IX, Clause – 36 of OPWD Code Vol.II vide Works Department letter No.12366/W dt.18.11.2013**).

- 3.26. If L1 bidder does not turn up for agreement after finalization of the tender, then he shall be debarred from participation in bidding for three years and action will be taken to blacklist the contractor. In that case, the L2 bidder, if fulfils, other required criteria would be called for drawing agreement for execution of work subject to the condition that L2 bidder

negotiates at par with the rate quoted by the L1 bidder otherwise the tender will be cancelled. In case a contractor is black listed, it will be widely published and intimated to all Departments of Government and also to Government of India agencies working in the State.

(As included in **Para 3.5.14 Note-I of OPWD Code Vol.I vide Works Department letter No.12366/W dt.18.11.2013**).

- 3.27. Before acceptance of tender, the successful bidder will be required to submit a work programme and milestone basing on the financial achievement so as to complete the work within the stipulated time and in case of failure on the part of the agency to achieve the milestone liquidated damaged will be imposed.

(As included in **Para 3.5.18 Note-VIII of OPWD Code Vol.I vide Works Department letter No.12366/W dt.18.11.2013**).

3.28. Grant of Concession to Scheduled Caste & Scheduled Tribe Contractors:

If the tender of the individual registered contractors belonging to Scheduled Caste and Scheduled Tribe is within 10% of the rate quoted by the lowest tenderer for any work, the work may be considered for award to him/her at the lowest tendered rate in the relaxation of Rule 18 of the O.G.F.R. Vol.I and Para 3.5.14 of OPWD Code Vol.I.

(**Resolution No.16/37 – 27748 Dated 11.10.1977 amended vide No.16262/W Dt.30.10.2018**).

SECTION - 4

SPECIAL CONDITIONS OF CONTRACT

4.1. Changes in Constitution of Firm:

In the case of tender by a partnership firm, any change in the constitution of the firm shall be forth with notified by the contractor to the **Project Engineer** for his information. In case of failure to notify the change in the constitution within 15 days, the **Project Engineer** may by notice in writing, rescind the contract and the security deposit of the contractor shall thereupon stand forfeited and be absolutely at the disposal of the Governor of Odisha and the same consequence shall ensure as if the contract had been rescinded thereof and in addition the contractor shall not be entitled to recover or be paid for any work there for actually performed under the contract.

4.2. Engineer's Access to Work:

The Project Engineer is to have at all times access to the works, which are to be entirely under his control. He may require the contractor to dismiss any person in the contractor's employ upon the works who may be incompetent or misconduct him-self and the contractor is forthwith to comply with such requirements. Other supervising officers shall have all time access to the works.

4.3. Workmen Compensation Act VIII of 1923:

The Governor of Odisha shall be entitled to recover in full from contractor any amount that the Governor of Odisha may be liable to pay under Workman's Compensation Act VIII of 1923 to any workman employed in course of execution of any part of the work covered by this contract.

4.4. Jurisdiction in the Event of Dispute:

That for the purpose of jurisdiction in the event of dispute if any, the contract should be deemed to have been entered into within the State of Odisha and it is agreed that neither party to this agreement will be competent to bring a suit in regard to the matters covered by this contract at any place outside Odisha.

4.5. Lighting & Sanitary Arrangement:

Lighting & Sanitary arrangement and supply of drinking water will be made by the Contractor at his own cost for his labour camp.

4.6. Payment of Duties, Levies & Taxes:

The Contractor shall bear all Taxes including Duties, Levies, Central and State Sales Tax including work Contract Tax, Entry Tax, Income Tax, Royalties, Fair Weather Charges and Tollages where necessary & **Government of Odisha** shall not entertain any claim whatsoever in this respect. Statutory deduction of taxes as applicable shall be done from each running bill.

4.7. The Building & Other Construction Workers Welfare Cess Act 1996:

In accordance with the provisions under the said Act 1% (One) of the approved agreement value will be deducted from the R/A Bill at the time of making payment to the contractor and such amount shall be remitted in favour of The Odisha Building & Other Construction Workers Welfare Board.

4.8. Site Clearance:

After the work is finished or completed, surplus materials and debris are to be removed by Contractor at his own cost and preliminary works such as vats, mixing platforms, level pillars, temporary sheds and go-downs etc. are to be dismantled and all such materials removed from site. The site involved in the construction activities should be cleared and dressed properly with outward slope away from the structure. After the work is completed in all respects as per the contract, the contractor shall vacate the site within three months from the date of completion & commissioning, by making good the damages if any.

4.9. Works to be carried Out:

The work to be carried out under the contract shall include all materials, labour, tools and plants, equipment and transport which may be required in preparation of and for in the full and entire execution and completion of the works. The description given in the schedule of quantities/scope of work shall, unless otherwise stated, be held to include wastage on materials, carriage & cartage, carrying and return of empties, hoisting, setting, fitting and fixing in position and all other labours necessary in and for the full and entire execution and completion of the work as aforesaid in accordance with good practice and recognized principles.

4.10. Coordination with consumer:

The contractor will take the consent of house owner for sewer house connection and construction of the chamber inside the property boundary, collect the form for sewer house connection from the consumer and coordinate sanction of connection with the PE(Sewerage), OISIP, JICA, OWSSB, Cuttack.

4.11. Sufficiency of Tender:

The contractor shall be deemed to have satisfied himself before tendering as to the correctness and sufficiency of his tender for the works and of the rates and prices quoted in the schedule of quantities (DTCN), which rates and prices shall, except as otherwise

provided, cover all his obligations under the contract and all matters and things necessary for the proper completion and commissioning of the works.

4.12. Rates:

The Tenderer shall quote their offer on **Percentage Rate Basis (excess or less) over the estimated cost in the Price Bid appended to the tender document** for the complete work in all respects. **The estimated cost is excluding GST. The rates of item basing on which estimated cost has been derived are excluding GST on different components to arrive at such rates.** The offer shall be inclusive of cost of all materials, labour, T&P inclusive of all duties, levies, taxes of Central and State Government including Works Contract tax the building and other construction workers welfare cess with surcharge, entry tax, tollages, royalties, packing and forwarding, transportation, insurance, loading & unloading, storage, watch and ward, delivery of the materials to the site etc. and all other expenses incidental thereto for successful completion, testing & commissioning of the work.

GST as applicable on works contract shall be paid over the bill amount at the time of Payment of Bill.

4.13. Billing Criteria:

The minimum value of any bill submitted by the contractor shall not be less than 5% of the total value of work in the contract agreement. Contractor will submit the bill after completion of all the sewer house connections in one lane (from node to node).

4.14. Transportation:

The contractor shall be responsible for the transportation of all materials, tools and plant, equipment and machinery to the work site as may be required at site.

4.15. Custody of the Materials:

The contractor shall be responsible for safe custody of the materials at site and the Governor of Odisha will not be responsible for any loss or damage of the property at site.

4.16. Construction Schedule:

The contractor shall submit a detailed work schedule in the form of **Bar Chart** along with his tender indicating the detailed break-up of the job. This will include all operations from procurement of materials to final testing at site to be indicated in detail with reference to the time period for each.

The construction schedule as submitted by the contractor shall be revised by the Project Engineer and approved with necessary modification if any after acceptance of the tender. The contractor shall furnish 6 copies of the approved schedule within a time to be intimated to him before drawl of the agreement. The approved Bar Chart shall form a part of the agreement. This approved schedule shall be binding on the contractor.

4.14(a) Progress reports – submission by the contractor

- (1) The contractor shall submit monthly progress report of the work in a computerised form. The progress report shall contain the following, apart from whatever else may be required as specified:
 - (i) Project information, giving the broad features of the contract.\
 - (ii) Introduction, giving a brief scope of the work under the contract, and the broad structural or other details.
 - (iii) Construction schedule of the various components of the work through a bar chart for the next three quarters (or as may be specified), showing the milestones, targeted tasks and upto date progress.
 - (iv) Progress chart of the various components of the work that are planned and achieved, for the month as well as cumulative upto the month, with reasons for deviations, if any, in a tabular format.
 - (v) Plant and machinery statement, indicating those deployed in the work, and their working status.
 - (vi) Man-power statement, indicating individually the names of all the staff deployed in the work, along with their designations.
 - (vii) Financial statement, indicating the broad details of all the running account payments received upto date, such as gross value of work done, advances taken, recoveries affected, amounts withheld, net payments, details of cheque payments received, etc.
 - (viii) A statement showing the extra and substituted items submitted by the contractor, and the payments received against them, items pending for sanction /decision by the Department, broad details of the bank guarantees, indicating clearly their validity periods, broad details of the insurance policies taken by the contractor, if any, the advances received and adjusted.
 - (ix) Progress photographs, in colour, of the various items/ components of the work done upto date, to indicate visually the actual progress of the work.
 - (x) Quality assurance and quality control tests conducted during the month, with the results thereof.
 - (xi) **Besides above contractor shall have to submit the information required as per the decision taken in the Kick-off meeting headed by the concerned Engineer-in-Charge.**
- (2) The progress report submitted by the contractor shall be checked and certified by the Junior Engineer and the Assistant Engineer, and has to be reviewed by the General Manager and the Superintending Engineer, over their dated signatures.

- (3) Work of unique importance and character irrespective of the value of the work, should have videography undertaken at various stages of construction right from the day of start of work to date of completion / occupation, covering all major events, inspections, visits by dignitaries, etc.

4.17. Initial Security Deposit:

The tenderer whose tender is selected for acceptance shall make an security deposit of **2% (two percent)** of the accepted tender amount together with the earnest money deposited with the tender which forms the initial security deposit (ISD) within **7(seven) days** of issue of letter of intent and sign the agreement in the prescribed form within **10 (ten) days** of issue of letter of intent after depositing the balance ISD. The ISD shall be deposited in shape of NSC / POTD / Post Office Savings Bank Account / KVP/ Deposit Receipt in Schedule Bank duly pledged in favour of the **Project Engineer, OISIP, JICA (Sewerage), OWSSB, Cuttack**. No tender shall be accepted unless required amount of security money is deposited.

In addition to the **ISD, 5%** of the bill amount shall be deducted from each bill towards the security deposit. The earnest money deposit, the initial security deposit before and after acceptance of tender together with the subsequent deduction from the contractor's bill shall form part of the security deposit equivalent to 7% of the contract value for the due fulfilment of the contract.

The security deposit of the contractor shall be refunded only 12 (twelve) months after the date of completion of the work provided the final bill has been paid and defects if any rectified.

If however there is inevitable delay in payment of final bill, the earnest money deposit and initial security deposit forming part of the security deposit may be refunded on orders of competent authority.

4.18. Monitoring of the Project:

Time is the essence of the contract. The execution of the project shall be closely monitored to ensure that quality; cost & time of the project are not compromised in any manner.

The contractor shall submit monthly progress reports in a format as may be prescribed by the Engineer-in-charge. The monthly progress report shall be evaluated by the Project Engineer vis-à-vis the approved bar chart and any deficiency observed thereto shall be communicated to the contractor. The contractor shall have to make up the deficiencies within the specific time period communicated to him by the Project Engineer failing which the contractor shall be liable for action as per **Clause -4.26**.

In addition, the contractor shall submit monthly day-wise work program one month in advance to Project Engineer for approval under intimation to the **Project Engineer, OISIP, JICA (Sewerage), OWSSB, Cuttack**. to ensure speedy implementation of the work and effective monitoring at all levels. Failing to do so shall also invite action under **Clause - 4.26**.

4.19. Site Order Book:

A site Order Book shall be issued to the contractor by the Engineer-in-charge or his representative. The contractor shall keep this Book always at site and any special order or instruction to be issued to the contractor shall be recorded in this Book by the Engineer-in-charge or his representative. The contractor shall sign all orders and instructions as token of his knowledge about the same. The site Order Book shall be the property of the department but will remain during the period of the progress of the work with the contractor. The safe custody of the site Order Book during this period shall be the responsibility of the contractor. After completion of the work, the Book shall be returned back by the contractor to the Engineer-in-charge, which will be enclosed in the final bill.

4.20. Guarantee:

Default liability period is **12 (twelve) months** from the date of preliminary acceptance of the work conforming to provisions in scope of work. During this period, the contractor shall replace the defective materials if any or rectify the defects if any at his own cost as pointed out by the Engineer-in-charge to the satisfaction of the later.

4.21. Land:

The department may provide land if available for construction of site office to the contractor on payment of usual rent.

4.22. Unilateral Stoppage of Work:

Unilateral stoppage of work by the contractor without prior written permission of the Engineer-in-charge shall be considered as breach of contract and the Governor of Odisha reserves the right to take such actions as it may be deemed fit.

4.23. Resident Engineer:

The contractor shall engage for this work competent, qualified and authorised resident Engineers and Assistants to the satisfaction of the Engineer-in-charge. The Resident Engineer shall represent the contractor in his absence in receiving directions from officers of the Department, which will be binding on the contractor.

4.24. Force Majeure:

Neither the contractor nor the Project Engineer shall be considered in default in delayed performance of its obligation if such performance is prevented or delayed because of work to hostilities, revolution, civil commotion, epidemic, accident, fire, cyclone, flood, earthquake or because of any law and order proclamation, regulations or ordinance of the Government thereof or because of any act of God or for any cause beyond reasonable control of the party affected. Should one or both the parties be prevented from fulfilling their contractual obligations a state of force majeure lasting continuously for a period of 6 months, the two parties shall consult each other regarding the future execution of the contract for mutual settlement.

4.25. Damages to Persons and Property:

The contractor shall take every precaution not to damage or injure adjoining or other property of any persons. He shall indemnify and keep indemnified the employee against all claims for injuries or damages to any person or any such property (including surface or land or crops in site) which may arise out of or in consequence of any negligence or default on the representatives and against all claim, demands proceedings damages, costs, charges and expenses whatsoever in respect of or in relation thereto. The Department does not take any responsibility on this account.

4.26. Attention to Urgent Works:

If any urgent work in the opinion of Engineer-in-charge becomes necessary to be executed and the contractor is unable and unwilling at once to carry out, the Engineer-in-charge may by his own or through other agency carry it out, as he may consider necessary. All expenses incurred on it shall be recoverable from the contractor or be adjusted against any sum payable to him.

4.27. Safety Devices:

Scaffolding: Suitable scaffolding shall be provided for workmen for all works that cannot be safely done from the ground or solid construction except such short period of work as can be done safely from the ladders. When a ladder is used an extra labour shall be engaged for holding the ladder and if the ladder is used in carrying the materials, suitable foot holds and handholds shall be provided on the ladder.

- i) The Engineer-in-charge will have the right to inspect the scaffolding and centring etc. for the work and can reject partly or fully such structure if found defective in his opinion.
- ii) **Working Platforms:** Working platforms, gangways and stairways shall be constructed such that they do not sag unduly or unequally. If the height of the platforms or gangway or stairway is more than 3.25 meters above the ground or floor level, it shall be closely guarded, have adequate width and suitably fenced.
- iii) **Safe means of access:** Safe means of access shall be provided to all working platform and other working places.
- iv) **Precaution against Electrical Equipment:** Adequate precaution shall be taken to prevent danger from electrical equipment. Hand lamps shall be provided with Mesh guard, wherever required.
- v) **Preventing Public from Accident:** No materials on any of the sites shall be so stacked or placed as to cause danger or inconvenience to any person or public. The contractor shall provide all necessary fencing and light to protect the public from accident and shall be bound to bear expenses of defence or any suit action or other proceedings at law that may be brought by any persons for injury sustained owing to neglect of the above precaution and to pay any damages and cost which may be awarded in any such suit action or proceedings to any such person or which may with the consent of the contractor, be paid to compromise any claim by any

such person. The contractor not to come cause blockage of traffic /disruption of the traffic.

- vi) **Demolition:** Before any demolition work is commenced and also during process of work:
 - a) All roads and open areas adjacent to the work site shall either be closed or suitably protected,
 - b) No electric cable or apparatus which is liable to be a source of danger shall remain electrically charged,
 - c) All practical steps shall be taken to prevent danger to persons employed from the risk of fire, explosion or flooding,
 - d) No floor roof or other parts of the building shall be so over loaded with debris or materials as may render it unsafe.
- vii) **Personal safety equipment:** All personal safety equipment shall be made adequately available by the contractor for use of persons employed at the site of work and maintained in a condition suitable for immediate use. The contractor shall take adequate steps to ensure proper use of the equipment by persons concerned.
- viii) **Precaution against fire:** Suitable fire extinguishers, water and sand buckets shall be provided at the work site to tackle situations of fire.

4.28. Rescission of Contract:

Subject to other provisions contained in this clause the Project Engineer of the Department may without prejudice to his any other rights or remedy against the contractor in respect of any delay, inferior workmanship, any claims for damages and/or any other provisions of this contract or otherwise, and whether the date of completion has or has not elapsed, recommend the accepting authority to rescind the contract in any of the following cases:

- i) If the **contractor** having been given by the Project Engineer a notice in writing to rectify, reconstruct or replace any defective work or that the work is being performed in an inefficient or otherwise improper or un-workmen like manner shall omit to comply with the requirement of such notice for a period of seven days thereafter.
- ii) If the contractor being a company shall pass a resolution on the court shall make an order that the company shall be wound up or if a receiver or a **manager** on behalf of a creditor shall be appointed or if circumstances shall arise which entitle the court or the creditor to appoint a receiver or a manager or which entitle to court to make a winding up order.
- iii) If the contractor has, without reasonable cause, suspended the progress of the work with due diligence so that in the opinion of the Project Engineer (which shall be final & binding) he will be unable to secure completion of the work by the date of completion and continues to do so after a notice in writing of seven days from the Project Engineer.

- iv) If the contractor fails to comply with the provisions of **Clause - 4.15** & other relevant clauses mentioned elsewhere in this DTCN.
- v) If the contractor fails to complete the work within the stipulated date or items of the work with individual date of completion, if any stipulated, on or before such date(s) of completion and does not complete them within the period specified in a notice given in writing in that behalf by the Project Engineer.

When the contractor has made himself liable for action under any of the cases aforesaid, the **accepting authority** shall have the powers to rescind the contract (of which rescission notice in writing to the contractor under the hand of Project Engineers shall be conclusive evidence), **20% of the value of the left over work** will be realized from the contractor as Penalty.

4.28.1. In case of rescission of contract as per **Clause 4.26**, the contractor shall have no claim to compensation for any loss sustained by him by regions of having purchased or procured any materials or entered any engagement on account of or with a view to execute the work / performance of the contractor.

4.29(a) Conditions for Reimbursement of Levy/Taxes if Levied after Receipt of Tenders:

- i) All tendered rates shall be inclusive of all taxes and levies payable under respect statutes. However, pursuant to the Constitution (46th Amendment) Act, 1982, if any further tax or levy is imposed by Statute, after the last stipulated date for the receipt of tender including extensions if any and the contractor thereupon necessarily and properly pays such taxes/levies the contractor shall be reimbursed the amount so paid, provided such payments, if any, is not, in the opinion of the **Project Engineer, OISIP, JICA (Sewerage), OWSSB, Cuttack.** (whose decision shall be final and binding on the contractor) attributable to delay in execution of work within the control of the contractor.
- ii) The contractor shall keep necessary books of accounts and other documents for the purpose of this condition as may be necessary and shall allow inspection of the same by a duly authorised representative of the Department and/ or the Engineer-in-Charge and further shall furnish such other information/ document as the Engineer-in-Charge may require from time to time.
- iii) The contractor shall, within a period of 30 days of the imposition of any such further tax or levy, pursuant to the Constitution (Forty Sixth Amendment) Act, 1982, give a written notice thereof to the Engineer-in-Charge that the same is given pursuant to this condition, together with all necessary information relating thereto.

4.29(b) Other statutory duty, Tax such as I.T., VAT will be deducted at sources from the bills of the contractor and deposited with concerned authority.

4.29 (c) Royalty at the prevailing rate on minerals will be deducted from the bills of the contractor and deposited with concerned authority.

4.30 Fair Wages Clause:

- a) The contractor shall not employ for the purpose of this contract any person who is below the age of fourteen years and shall pay to each labourer for work done by such labourer's fair wages.

Explanation – "**Fair Wage**" means wages, whether for time or piece work prescribed by the State Public Works Department provided that where higher rates have been prescribed under the minimum wages Act 1948 wages at such higher rates should constitute fair wages.

The Project Engineer shall have the right to enquire into and decide any complaint alleging that the wages paid by the contractor to any labourer for the work done by such labourer is less than the wages as per sub-paragraph-I above.

- b) The contractor shall, notwithstanding the provisions of any contract to contrary, cause to be paid a fair wage to labourers indirectly engaged on the work including any labour engaged by his sub-contractors in connection with the said work, as if, the labourers had been immediately employed by him.
- c) In respect of all labour directly or indirectly employed in the works for the performance of the contractor's part of this agreement, the contractor shall comply with or cause to be complied with all regulations made by Government in regard to payment of wages, wage period deductions from wages, recovery of wages not paid and deductions unauthorisedly made, maintenance of wage register, wage cards, publication of scale of wages and other terms of employment, inspection and submission of periodical returns and all other matters of a like nature.
- d) The Project Engineer or Sub-Divisional Officer concerned shall have the right to deduct, from the money due to the contractor, any such required or estimated to be required for making good the loss suffered by a worker or workers by reason of non-fulfilment of the conditions of the contract for the benefit of the workers non-payment of wages or of deduction made from his or their wages, which are not justified by their terms of the contract or non-observance of the regulations. Money so deducted should be transferred to the workers concerned.
- e) Vis-à-vis, the Government of Odisha, the contractor shall be primarily liable for all payments to be made under and for the observance of the regulations aforesaid without prejudice to his right to claim indemnity from his sub-contractor.
- f) The regulations aforesaid shall be deemed to be a part of this contract and any breach thereof shall be breach of this contract.

[Odisha PWD / Electricity Department Contractor's Labour Regulations]

4.30.1 Short title – These regulations may be called “**The Odisha Public Works Department / Electricity Department Contractor's Regulations**”.

4.30.2 Definitions – In these Regulations, unless otherwise expressed or indicated the following words and expressions shall have the meaning here by assigned to them respectively, that is to say -

- i) “**Labour**” means a worker employed by the contractor directly or indirectly through a sub-contractor or other person, or by an agent on his behalf.
- ii) “**Fair Wages**” means wages whether for time or piece work prescribed by the State Public Works Department provided that where higher rates have been prescribed under the minimum wages Act, 1948 wages at such higher rates should constitute fair wages.
- iii) “**Contractor**” shall include every person whether a sub-contractor or headman or agent employing labour on the work taken on contract.
- iv) “**Wages**” shall have the same meaning as defined in the payment of Wages Act and include time and piece rate wages, if any.

4.30.3 Display of Notices regarding Wages, etc.:

The contractor shall:-

- a) Before he commences his work on contract display and correctly maintain and continue to display and correctly maintain, in a clean and legible condition, in conspicuous places on the work, notices in English and in the local Indian language spoken by the majority of the workers, giving the rate of wage prescribed by the State Public Works Department / Electricity Department for the district in which the work is done.
- b) Send a copy of such notices to the Engineer-in-charge of the work.

4.30.4 Payment of wages:

- 1) Wages due to every worker shall be paid to him direct.
- 2) All wages shall be paid in current coin or currency or in both

4.30.5 Fixation of wage period:

- 1) The contractor shall fix the wage period in respect of which the wages be payable.
- 2) No wage period shall exceed one month.

- 3) Wages of every workman employed on the contract shall be paid before the expiry of ten days, after the last day of the wage period in respect of which the wages are payable.
- 4) When the employment of any worker is terminated by or on behalf of the contractor, the wages earned by him shall be paid before the expiry of the day succeeding the one on which his employment is terminated.
- 5) All payments of wages shall be made on a working day.

4.30.6 Wage book and wages cards, etc.:

- 1) The contractor shall maintain a wage book of each worker in such form as may be convenient, but the same shall include the following particulars-
 - a) Rate of daily or monthly wages.
 - b) Nature of work on which employed
 - c) Total number of days worked during each wage period
 - d) Total amount payable for the work during each wage period.
 - e) All deductions made from the wages with an indication in each case of the ground for which the deduction is made.
 - f) Wage actually paid for each wage period.
- 2) The contractor shall also maintain a wage card for each worker employed on the work.
- 3) The Project Engineer may grant an exemption from the maintenance of wage bond, wage cards to a contractor who, in his opinion – may not directly or indirectly employ more than 100 persons on the work.

4.30.7 Fines and deduction which may be made from wages:

- i) The wages of a worker shall be paid to him without and deduction of any kind except the following -
 - a) Fines
 - b) Deductions for absence from duty, i.e., from the place of places whereby the terms of his employment he is required to work. The amount of deductions shall be in proportion to the period for which he was absence.
 - c) Deductions for damage to or loss of good expressly entrusted to the employed person for custody or for loss of money for which he is required to account where such damage or loss is directly attributable to his neglect or default.

- d) Any other deductions which the Odisha Government may from time to time allow.
- ii) No fines shall be imposed on a worker and no deduction for damage or loss shall be made from his wages until the worker has been given an opportunity of showing cause against such fines or deduction.
- iii) The total amount of fines which may be imposed in any one wage period on a works shall not exceed an amount equal to five paise in a rupee of the wages payable to him in respect of that wage period.
- iv) No fine imposed on any worker shall be recovered from him by installments, or after the expiry of 60 days from the date on which it was imposed.

4.30.8 Register of fines, etc.:

- i) The contractor shall maintain a register of fines and of all deduction for damage or loss. Such register shall mention the reason for which fine was imposed or deduction for damage or loss was made.
- ii) The contractor shall maintain a list in English and in the local Indian language, clearly defining acts and omissions for which penalty of fine can be imposed. It shall display such list and maintain it in a clean and legible condition in conspicuous places on the work.

4.30.9 Preservation of register:

The wage register, the wage cards and the register of fines, deduction required to be maintained under the regulations shall be **preserved for 12 (twelve) months** after day of the last entry made in them.

4.30.10 Powers of Labour Welfare Officers to make investigation or enquiry:

The Labour Welfare Officers or any other persons authorized by the Government of Odisha on their behalf shall have power to make enquiries with a view to ascertaining and enforcing due and proper observance of the fair wage clauses and the provisions of these regulations. He shall investigate into any complaint regarding default made by the contractor, sub-contractor in regard to such provisions.

4.30.11 Report of Labour Welfare Officers:

The Labour Welfare Officer or others authorized as aforesaid shall such a report of the results of his investigation or enquiry to the Project Engineer concerned, indicating the extent, if any, to which the default has been committed with a note that necessary deductions from the contractor bill be made and the wages and other dues be paid to the labourers concerned.

4.30.12 Appeal against the decision of Labour Welfare Officer:

Any persons aggrieved by the decision and recommendation of the Labour Welfare Officer or other person so authorized may appeal against such decision to the Labour Commissioner within 30 days from the date of decision forwarding simultaneously a copy of his appeal to the Project Engineer concerned but subject to such appeal, the decision of the officer shall be final and binding upon the contractor.

4.30.13 Inspection of register:

The contractor shall also allow inspection of the wage book and wage cards to any of his workers or to his agent at a convenient time and place after due notice is received, or to the Labour Commissioner or any other person authorized by the Government of Odisha on his behalf.

4.30.14 Submission of return:

The contractor shall submit periodical returns as may be specified from time to time.

4.30.15 Amendments:

The Government of Odisha may from time to time, add to or amend these regulations and on any question as to the application, interpretation of effect of these regulations, the decision of the Labour Commissioner or any other person authorized by the Government of Odisha in that behalf shall be final.

The terms and conditions of the agreement have been read by Me/ Us and I/ We certify that I/We clearly understand them and agree to abide by them.

Contractor

SECTION - 5

SCOPE OF WORK AND TECHNICAL SPECIFICATIONS

5.1. Scope of Work

Orissa Water Supply and Sewerage Board (OWSSB) is implementing the project Sewerage System for Cuttack city, under JICA assisted Odisha Integrated Sanitation Improvement Project (OISIP). The Cuttack Sewerage System project area comprises of around 47 sq. km area of Cuttack city bounded by river Mahanadi on the Northern side and river Kathajodi on the Southern side. The project includes 362 km of sewer network (331 km of RCC gravity sewer and 31 km of DI pumping mains). Cuttack Sewerage Project is divided in to 14 Nos. of zones and sub zones i.e. Zone-1, 2, 3A, 3B, 3C, 3D, 5A, 5B, 6A, 6B, 6C, 6D, 7A, and 7B.

In order to expedite the house sewer connections, the sewer connection outside the property boundary and a chamber inside property boundary (If required for House Connection) are to be executed by OISIP, OWSSB. This tender document has been prepared for all Packages (1-12) and potential house connections in each zone are defined below:

The House Connections to the Sewerage System, Cuttack

The scope of work for '**The House Connections to the Sewerage System, Cuttack**' includes the work related to house sewer connection, outside the house property, i.e. from Inspection Chamber constructed near the property boundary (constructed by OISIP) up to a brick masonry chamber constructed inside property boundary.

Package	Zone	Potential House Connections (Nos.)
1.	Zone-1 & 7A	3376
2.	Zone-2	5110
3.	Zone-3A	4003
4.	Zone-3B	4287
5.	Zone-3C	2145
6.	Zone-3D	5867
7.	Zone-5A	2542
8.	Zone-5B	2689
9.	Zone-6A	2137
10.	Zone-6B & 6C	2269
11.	Zone-6D	2902
12.	Zone-7B	3733

- 1) The contractor will take the consent of house owner for sewer house connection and construction of the chamber inside the property boundary, collect the form for sewer house connection from the consumer and coordinate sanction of connection with the PE(Sewerage), OISIP, JICA, OWSSB, Cuttack.
- 2) The house connection work outside the property boundary shall include:
 - i) road breaking,
 - ii) excavation,

- iii) making opening in Inspection Chamber for connection,
- iv) a Brick Masonry Chamber of internal dimension 450x450mm constructed inside the property boundary (If required for Sewer House Connection).
- v) laying the 110 mm dia PVC pipe line, with sand bedding, from existing Inspection Chamber constructed by OISIP, OWSSB (in ROW of road), up to a Brick Masonry Chamber (constructed inside property boundary or sewer line from the house (near the property boundary).
- vi) PVC pipe shall be laid to appropriate level and gradient etc., connected to inspection chamber at one end and to brick masonry chamber/house sewer line on the other end, and grouting of the opening made in the inspection chamber, removal of debris from the inspection chamber,
- vii) backfilling of the excavation with selected excavated earth,
- viii) conducting flow test to ensure uninterrupted flow of sewage from the house to existing inspection chamber constructed by OISIP, OWSSB,
- ix) restoration of the damaged road to the original condition by Cement Concrete (1:1.5:3) etc.

5.2. Technical Specifications:

5.2.1. General:

The following general requirements shall be followed by the Contractor:

- i) All works shall be executed in line with Technical Specifications and Drawings approved by Engineer in Charge.
- ii) During construction all the conditions as per the Government of Odisha, PWD Code shall be followed.
- iii) All the safety precautions shall be taken by the contractor to avoid any damage/incident.
- iv) Electric pole, telephone cable, water supply pipe lines, trees etc. should be protected as far as possible.
- v) Suitable arrangement must be made for street drainage if required at site.
- vi) The Odisha PWD and PHD specification will be followed for all the works.
- vii) The cleaning and removal of debris etc. shall be carried out side by side during the execution of the work as well as on completion.
- viii) The contractor shall make his own arrangements for water required for construction purpose at his own cost.

- ix) Actual quantities of completed and accepted work by employer will be paid for.
- x) The contractor will arrange his own tools, plant and equipment required for work.
- xi) All the work including supply of materials to be executed as per relevant IS specification and direction of Engineer-in-charge.
- xii) Contractor shall take the consent of house owner for construction of chamber inside the property boundary as required, collect the request form for sewer house connection from the consumer and co-ordinate sanction of connection from PE(Sewerage), OISIP, JICA, OWSSB, Cuttack.
- xiii) After sanctioning of house connection by OWSSB, sanction letter will be forwarded to contractor by Email/WHATSAPP/Hand delivery.
- xiv) On receipt of sanction letter, Contractor's staff along with OWSSB/PMC representative will visit the house and finalise the procedure and time of connection, in consultation with the house owner.
- xv) Responsibility to make each house connection functional will lie with the contractor.
- xvi) OWSSB/PMC representatives will help contractor in resolving any local issues.
- xvii) Contractor shall complete each house connection within 7 days of sanctioning of house sewer connection by OWSSB.
- xviii) Contractor will raise the RA Bill for a minimum billing amount, not less than 5% of contract value.
- xix) On completion of all the sewer connection to all the houses in one lane (from node to node) it will ne considered for payment.

5.2.2. Breaking of the Road:

For the House Sewer Connection work, CC/BT road shall be broken in minimum width required for laying of 150 mm dia RCC NP3 pipe, so that there is minimum damage to the road surface.

5.2.3. Trench Excavation for Pipe Laying:

Trench shall be excavated in minimum width required, for laying of house sewer connection pipe.

5.2.4. Bedding:

A 100 mm thick sand layer shall be provided at the bottom of the trench and compacted properly to give a firm and even base for laying of house sewer connection pipe.

5.2.5. House Sewer Connection:

House sewer connection shall be done by laying 110 mm dia, PVC pipe conforming to relevant IS specification of 6 kg/cm², connecting chamber/sewer pipe at the property boundary to the nearest, existing Inspection Chamber constructed by OISIP, OWSSB. Pipe shall be laid at a minimum gradient of 1:50, flowing from house to OISIP Inspection

Chamber. All the debris shall be cleared from the Inspection Chamber, after completion of the work.

5.2.6. Connection with Inspection Chamber:

PVC pipe shall be connected to the bottom portion of nearest OISIP Inspection Chamber (IC) by cutting a hole in the IC. After connecting the PVC pipe to IC, the hole shall be grouted with 1:1 (Cement: Sand) mortar, to make it waterproof.

5.2.7. Brick Masonry Chamber:

If required for house connection, a brick masonry chamber shall be constructed inside the property boundary. The brick masonry chamber shall be of approximate internal size 450x450mm and approximately 600 mm depth, 250 mm wall thickness, brick masonry shall be in 1:4 (cement : sand) mortar, 12 mm thick internal and outside cement plaster in 1:4 (cement : sand) mortar, benching in CC (1:2:4), inside neat cement punning, Pre-cast Concrete cover shall be of square shape, 450mmx450mm size, of Grade LD-2.5 as per IS 12592 etc..

5.2.8. Water Flow Test:

After completion of house sewer connection, before backfilling of trench, flow test shall be done by putting a bucket of water in the chamber inside property boundary to ensure free flow of water from the chamber inside property boundary to the Inspection Chamber.

5.2.9. Water Line Crossing:

In case of any water line between the inspection chamber and property boundary, the house sewer connection will cross from below the water line, without disturbing/damaging the water line. Any damages to water line shall be restored by the contractor at his own cost.

5.2.10. Storm Water Drain Crossing:

In case of any storm water drain between the inspection chamber and property boundary, if the depth of the drain is up to 500 mm, the house sewer connection line will cross from below the storm water drain by blocking the drain on both sides. Any damage or collapse of the drain shall be restored by contractor. Payment for restoration of storm water drain shall be claimed by the contractor for items executed, at BOQ rates.

In case, the depth of the drain is more than 500 mm, the house sewer connection line will cross the storm water drain in the freeboard area on the top of drain, so that the sewer house connection does not obstruct the storm water flow in the drain. The damages to the drain shall be restored by contractor. Payment for restoration of storm water drain shall be claimed by the contractor for items executed, at BOQ rates.

5.2.11. Back Filling with Earth:

After completing the House Sewer Connection and flow test, the trench shall be backfilled with selected excavated earth in layers followed by compaction by watering and ramming.

5.2.12. Road Restoration:

After thoroughly compacting of sand filling, road shall be restored with 200 mm thick layer of cement concrete (1:1.5:3), matching with the road top level.

5.2.13. Disposal of Surplus Excavated Material:

Surplus excavated material and debris shall be disposed within 50 m distance, as directed by the Engineer-In-Charge.

5.2.14. Housekeeping:

After completion of work the site will be cleared of all construction material, tools and plants etc. and properly cleaned by the contractor.

5.3 Detail Description of Items in Bill of Quantity (BOQ)

A Road Cutting/Restoration:

- A.1 Supplying all labour and T&P and dismantling the road for laying house sewer pipes, construction of inspection chambers etc, and depositing the excavated materials within initial lead of 50 m including barricading, lighting, watch & ward etc all complete as per specification and direction of the Engineer.
- A.2 Supplying all material, labour and T & P and providing 200 mm thick cement concrete (1:1 1/2:3) using 12mm down hard granite chips, including hoisting and laying concrete, levelling and making surface smooth, watering for curing etc all complete including cost, conveyance, taxes and duties all complete as per specification and as per the direction of the Engineer.

B. Laying of PVC Pipe from SCC/IC to Property Chamber (Inside Boundary):

- B.1 Supplying all labour and T & P and earthwork in excavation in all kinds of soil in trenches for laying of house sewer connection pipes, inspection chambers etc. including dressing and levelling the bed and depositing the excavated materials within 50 meters initial lead including barricading, watch & ward, lighting and bailing out water of trenches if necessary etc. all complete as per the drawing, specification and direction of the Engineer Up to 1.5m B.G.L
- B.2 Providing, laying, joining of 110 mm PVC Pipe (Material Grade PE 100) and Pressure rating conforming to relevant IS specification of 6 kg/cm² to the required level and gradient, testing etc. complete as per the drawings, specifications and the instructions of the Engineer.
- B.3 Supplying all labour, T&P and filling the trenches of pipe line & house sewers etc. with sand including all taxes & duties up to required depth in layers not exceeding 100mm thick including watering & ramming all complete as per specification and direction of the Engineer.
- B.4 Supplying all labour, T&P and refilling the trenches of house sewer pipe and inspection chambers etc. with excavated earth including all taxes & duties up to required depth in layers not exceeding 150mm thick including watering & ramming all complete as per specification and direction of the Engineer.

C. Making Connection with existing MH/SCC/IC

- C.1 Cutting Hole Through existing Brick Work and making the same in good condition for taking pipes
- C.2 Making Connection with existing MH/SCC/IC and grouting the hole/cavity with Cement Sand Mortar (1:1) to make it waterproof.

D. Drain Crossing and Repairing:

- D.1 Supplying all labour and T&P and dismantling of RCC construction including stacking the useful materials and removing the debris within 50m lead as per the direction of the Engineer.
- D.2 Supplying all labour and T&P and dismantling of Plain Cement Concrete work including stacking the useful materials and removing the debris within 50m lead as per the direction of the Engineer.
- D.3 Supplying all material, labour and T & P and constructing brick work with K.B. bricks having crushing strength not less than 75 kg/cm² in CM (1:4) including curing, bailing out water if necessary etc including all taxes and duties all complete as per specification and direction of the Engineer.
- D.4 Supplying all material, labour and T & P and constructing cement concrete (1:3:6) work with 40mm size hard broken granite metals including curing ,bailing out water if necessary etc all complete as per specification and direction of the Engineer.
- D.5 Supplying all material, labour and T & P and constructing RCC work in M20 nominal mix (1:1.5:3) with 20mm and downgraded crusher broken black hard granite, providing reinforcement steel as required, centering & shuttering ,hoisting and laying of concrete, curing etc. including all taxes and duties all complete as per specification and direction of the Engineer.
- D.6 Supplying all material, labour and T & P and plastering with 12mm thick cement plaster with cement mortar (1:4), with neat cement punning over brick work including all taxes and duties all complete as per specification and direction of the Engineer.
- D.7 Supplying all material, labour and T & P and plastering with 16mm thick cement plaster with cement mortar (1:4) over brick work including etc all taxes and duties all complete as per specification and
- D.8 Supplying all material , labour and T & P and plastering with 20mm thick cement plaster with cement mortar (1:4) over stone work including etc all taxes and duties all complete as per specification and direction of the Engineer.

E. Construction of Chamber inside Property Boundary

- E.1 Supplying all labour and T & P and earthwork in excavation in all kinds of soil in trenches for laying of house sewer connection pipes, inspection chambers etc. including dressing and levelling the bed and depositing the excavated materials within 50 meters initial lead including barricading, watch & ward, lighting and bailing out water of trenches, if necessary, etc. all complete as per the drawing, specification and direction of the Engineer.
- E.2 PCC (1:3:6): Supplying all material, labour and T & P and constructing cement concrete (1:3:6) work with 40mm size hard broken granite metals including curing, bailing out water if necessary etc all complete as per specification and direction of the Engineer.

- E.3 RCC (1:1.5:3) : Supplying all material ,labour and T & P and constructing RCC work in M20 nominal mix (1:1.5:3) with 20mm and downgraded crusher broken black hard granite, providing reinforcement steel as required, centering & shuttering ,hoisting and laying of concrete, curing etc. including all taxes and duties all complete as per specification and direction of the Engineer.
- E.4 Brick Work : Supplying all material, labour and T & P and constructing brick work with K.B. bricks having crushing strength not less than 75 kg/cm² in CM (1:4) including curing, bailing out water if necessary etc including all taxes and duties all complete as per specification and direction of the Engineer.
- E.5 Outside Plastering: Supplying all material, labour and T & P and plastering with 16mm thick cement plaster with cement mortar (1:4) over brick work including etc all taxes and duties all complete as per specification and direction of the Engineer.
- E.6 Inside Plastering: Supplying all material, labour and T & P and plastering with 12mm thick cement plaster with cement mortar (1:4), with neat cement punning over brick work including all taxes and duties all complete as per specification and direction of the Engineer.
- E.7 CC (1:2:4) : Supplying all material, labour and T & P and constructing cement concrete (1:2:4) work with 12mm size hard broken granite chips including curing ,bailing out water if necessary etc, including all taxes and duties all complete as per specification and direction of the Engineer.
- E.8 Providing and fixing of Precast Concrete Cover Square (450x450) mm of Grade LD-2.5, As per IS-12592:2002 complete as per specification.

5.4 Drawings:

The following drawings are for reference and are part of the tender Document

S. No.	Drawing No.	Description	Total Number of Drawings
1.	TD/HSC/Z-1/01	Typical Detail of Pipe Trench, Bedding and Chamber	1
2.	TD/HSC/Z-1/02	Sewer Layout Zone-1, Cuttack	1
3.	TD/HSC/Z-2/03	Sewer Layout Zone-2, Cuttack	1
4.	TD/HSC/Z-3A/04	Sewer Layout Zone-3A, Cuttack	1
5.	TD/HSC/Z-3B/05	Sewer Layout Zone-3B, Cuttack	1
6.	TD/HSC/Z-3C/06	Sewer Layout Zone-3C, Cuttack	1
7.	TD/HSC/Z-3D/07	Sewer Layout Zone-3D, Cuttack	1
8.	TD/HSC/Z-5A/08	Sewer Layout Zone-5A, Cuttack	1

9.	TD/HSC/Z-5B/09	Sewer Layout Zone-5B, Cuttack	1
10.	TD/HSC/Z-6A/10	Sewer Layout Zone-6A, Cuttack	1
11.	TD/HSC/Z-6B/11	Sewer Layout Zone-6B, Cuttack	1
12.	TD/HSC/Z-6C/12	Sewer Layout Zone-6C, Cuttack	1
13.	TD/HSC/Z-6D/13	Sewer Layout Zone-6D, Cuttack	1
14.	TD/HSC/Z-7A/14	Sewer Layout Zone-7A, Cuttack	1
15.	TD/HSC/Z-7B/15	Sewer Layout Zone-7B, Cuttack	1
TOTAL DRAWINGS IN ANNEXURE-III			15

All provisions of the technical scope of work & terms & conditions of the contract have been read by Me/Us and I/We certify that I/We clearly understand them & agree to abide by them.

Witness

Contractor

SCHEDULE – A STRUCTURE & ORGANISATION

Bid Identification No: 01 Dt. 25.04.2022

Name of the Work: Construction for the House Connections to the Sewerage System – **Package/Zone:**, Cuttack

1. General Information

a) Name of Applicant:

b) Head Office Address:

e-Mail Address:

Telephone No.:

Fax :

Mobile Phone No.

c) Regional Office Address (if any):

e-Mail Address:

Telephone No.:

Fax :

d) Local Office (if any):

e-Mail Address:

Telephone No.:

Fax :

e) Class of contractor / firm and year of incorporation:
(attach copy of certificate of registration)

f) Name and Address of Bankers:

g) Main Lines of Business:

SCHEDULE – B METHOD STATEMENT

Bid Identification No: 01 Dt. 25.04.2022

Name of the Work: Construction for the House Connections to the Sewerage System **Package/Zone:**, Cuttack

SCHEDULE – C
INFORMATION REGARDING CURRENT LITIGATION,
DEBARRING / EXPELLING OF TENDER OF ABANDONMENT
OF WORK BY TENDER

Bid Identification No: 01 Dt. 25.04.2022

Name of the Work: Construction for The House Connections to the Sewerage System **Package/Zone:**, Cuttack

1. (a) Is the applicant currently involved in any litigation relating to any contract works - **Yes/No**

(b) If yes, give details

2. (a) Has the applicant or any of its constituent partners have been debarred / expelled by any agency in India during the last 5 years - **Yes/No**

(b) If yes, give details

3. (a) Has the applicant or any of its constituent partners failed to perform/absconded/ rescinded on any contract work in India during the last 5 years - **Yes/No**

(b) If yes, give details

Note : If any information in this schedule is found to be incorrect or concealed pre-qualification application will be summarily rejected.

Signature of the bidder

SCHEDULE – D DECLARATION BY THE TENDERER

Bid Identification No: 01 Dt. 25.04.2022

Name of the Work: Construction for The House Connections to the Sewerage System **Package/Zone:**, Cuttack

**To The Engineer-in-Chief, OISIP, JICA,
OWSSB, Cuttack**

1. I/We have visited the site and have fully been acquainted myself/ourself with the local situation regarding materials, labour and the factors pertaining to the work before submitting the tender.
2. I/We have carefully studied the conditions of the contract, specification and other documents of this work and I/We agree to execute the same accordingly.
3. I/We solemnly pledge that I/We shall be sincere in discharging my/our duties as responsible contractor and complete the work within the prescribed time limit. I/We shall submit detailed construction programme with target dates for various items and stages of work keeping in view the time limit and shall accordingly arrange for necessary labours, materials, and equipments etc., punctually. In case there are deviations from the construction programme, I/We shall abide by the decision of the Engineer-incharge for revision of the programme and shall arrange for labour, materials, equipments etc
4. I/We shall follow all rules and regulations of the state in force with regard to engagement of labour for the work.
5. The documents furnished with the tender are correct to the best of my/our knowledge and belief and if any information found to be incorrect in future, the Department has the liberty to take any action as deemed fit.
6. Should this tender be accepted I/We hereby agree to abide by and fulfil all the terms and provisions of the said conditions and special conditions of the contract annexed hereto or in default thereof to forfeit and pay to the Governor of Odisha the sums of money mentioned in the said conditions and in the event of such default the transaction effected by this tender shall cease and determine.

Date:

Place: **Signature of the Tenderer**

Name/Organisation

Seal

SCHEDULE – E AFFIDAVIT

Bid Identification No: 01 Dt. 25.04.2022

Name of the Work: Construction for The House Connections to the Sewerage System
Package/Zone:, Cuttack

**To The Engineer-in-Chief, OISIP, JICA,
OWSSB, Cuttack**

1. I/We _____ certify that all information furnished is true and agree that my / our Tender shall be rejected if I / we am / are found to have misled or made false representation in the form of any of the Schedules of Supplementary information and / or statements submitted in proof of the eligibility and qualification requirements or if I / We have a record of poor performance such as absconding from work, works not properly completed as per contract, inordinate delays in completion, financial failure and / or has / have participated in previous Tendering for the same work/s and had quoted unreasonable high Tender premium. In addition I/we shall be blacklisted and the work be taken over invoking relevant clause of the General conditions of contract and conditions of particular application.
2. I/We _____ certify that no criminal cases are pending against me/us partners at the time of submitting the Tender.
3. I/We _____ accept that my / our Tender shall be rejected if any criminal cases are pending against me/us/partners of the firm at the time of submitting the Tender.
4. I/We _____ agree that if the history of litigation, criminal cases pending against me/us/Partners furnished by me/us is false, I / We _____ will attend by the action taken by the H&U.D. Deptt., without approaching any court whatsoever for redress. However, I/We shall be given suitable opportunity to offer my/our explanation before action is taken against me/us.
5. I/We _____ certify that the following addenda issued by the The Engineer-in-Chief, OISIP, JICA, OWSSB, Cuttack have been received by me/us and incorporated in my/ our Tender.
 1. _____ dated _____
 2. _____ dated _____
 3. _____ dated _____

(Add if the addenda issued are more than 3)

6. 6. Further I/We _____ certify that no near relatives in the cadre of an Assistant Engineer or above are working in the OFFICE OF THE ENGINEER-IN-CHIEF, OISIP, JICA, OWSSB (A Government of Orissa Undertaking).
7. I / We _____ certify that the technical specification for which I have quoted rate is as per the requirement of the DTCN.

Dated this day of 2022.

Signature in the capacity of duly authorized to sign the Tender for and on behalf of

.....

(Block Capitals)

Signature of Witness:

Name of Witness:

Address of Witness:

SCHEDULE – F
ANY OTHER INFORMATION, IF ANY

Bid Identification No: 01 Dt. 25.04.2022

Name of the Work: Construction for The House Connections to the Sewerage System **Package/Zone:** , Cuttack

(a) Performance Certificate(s):

The Following Performance Certificate is/are enclosed.

Sl. No.	Name of Construction	Name of Employer	Commencement date	Completion Date

(b) Other Information, if any

List of Information enclosed, if any.

- (i)
- (ii)
- (iii)
- (c)

SCHEDULE - G FORM OF BID-SECURITY DECLARATION

(As per Finance Department O.M. No.8943 Dt.18.03.2021 & No.18281 Dt.31.12.2021)

Bid Identification No: 01 Dt. 25.04.2022

Name of the Work: Construction for The House Connections to the Sewerage System
Package/Zone:, Cuttack

To **The Engineer-in-Chief, OISIP, JICA,
OWSSB, Cuttack**

Sir,

I/We the under signed, declare that:

1. I/We understand that, according to your conditions, bids must be supported by a Bid-Security Declaration.
2. I/We accept that the Authority/ Employer/ Tender Inviting Authority shall cancel our empanelment, and / or suspend/ prohibit/ debar/ blacklist from participating in bidding in any contract of the State for a minimum period of 180 days, if we are in breach of our obligation (s) under the bid conditions, because we:
 - (a) have withdrawn our Bid prior to the expiry date of the bid validity specified in the Letter of Bid or any extended date provided by us; or
 - (b) having been notified of the acceptance of our Bid by the Employer prior to the expiry date the bid validity in the Letter of Bid or any extended date provided by us,
 - i. fail or refuse to furnish the performance Security and, Additional performance Security, if required in accordance with the ITB/ Terms of the Bid Document/RFP, or
 - ii. fail to agree to the decisions of the contract negotiation meeting or
 - iii. Fail or refuse to execute the Contract.
3. I/We understand this Bid-Security Declaration shall expire if we are not the successful Bidder, upon the earlier of your notification of the name of the successful Bidder, through award of contract (ii) after the expiry date of the Bid validity.
4. I/We also understand that this declaration has to be submitted along with the bid and claim in a subsequent date will not be considered by the tender inviting authority.

Name of the Bidder* _____

Name of the person duly authorized to sign the Bid on behalf of the Bidder** _____

Title of the person signing the Bid

Signature of the person named above

Date of Signature

*: In the case of the Bid submitted by joint venture specify the name of the joint Venture as Bidder

** : Person signing the Bid shall have the power of attorney given by the Bidder attached to the Bid

Note: In case of a Joint Venture, the Bid-Security Declaration must be in the name of all members to the Joint Venture that submits the bid].

ANNEXURE – I:

**Guidelines/Procedure to be followed
in Introduction of e-Procurement in
Govt. of Odisha**

Executive Instruction regarding calling for and acceptance of tenders in e-Procurement in Govt. of Odisha.

**Government of Odisha
Works Department**

Office Memorandum

File No.07556900042013 (Pt-II) –7885/W Dated 23.07.2013

Sub: Codal Provision regarding e-Procurement

After introduction of e-procurement in Government of Odisha, necessary guidelines / procedures has been issued in Works Department Office Memorandum No.1027 dt.24.01.2009 which consists of the procedural requirement for e-procurement of tenders. After careful consideration Government have been pleased to make following modifications to codal provisions by way of addition as Appendix – IX(A) of OPWD Code Vol.II) as follows:

(Appendix-IX (A) of OPWD Code, Vol-II)

Executive instructions regarding calling for and acceptance of tenders in e-Procurement.

1. This office memorandum consists of the procedural requirement of e-procurement and shall be made part of the Detailed Tender Call Notice or Instruction to Bidder for all "works" tenders hoisted in the portal.
2. The e-procurement portal of Government of Odisha is "<https://tendersodisha.gov.in>".
3. Use of valid Digital Signature Certificate of appropriate class (Class II or class III) issued from registered certifying authorities (CA) as stipulated by Controller of Certifying Authorities (CCA), Government of India such as n-Code, Sify, TCS, MTNL, e-Mudhra is mandatory for all users.
4. The DSC issued to the Department users is valid for the period of two years only. All the Department users are responsible to revalidate their DSC prior to expiry.
5. For all purpose, the server time displayed in the e-Procurement portal shall be the time to be followed by all the users.
6. Government after careful consideration have decided to hoist all tenders costing 10 lakhs or above in the e-procurement portal. This will be applicable across all Engineering Departments such as Works Department, Department of Water Resources,

Rural Development and Housing & Urban Development Department. Government of Odisha also welcomes hoisting of tenders by any other departments, authority, corporations, local bodies etc. of the State with prior approval from Works Department. Works Department is the Nodal Department for the implementation of e-Procurement in the State.

7. The e-procurement shall be operated compliant to relevant provisions of OGFR/ OPWD code/ Accounts code/ Government statues including any amendments brought from time to time to suit to the requirement of the best national practice.
8. Registration in the e-procurement portal is without levy of any charges but Government reserves the right to levy any charges for such value added services in future.
9. Contractor not registered with Government of Odisha, can participate in the e-Procurement after necessary enrolment in the portal but have to subsequently register themselves with the appropriate registering authority of the State Government before award of the work as per prevalent registration norms of the State.
10. For the role management "Department" is the Administrative Department, Organisation or wing is the Chief Engineer or highest tender accepting authority or equivalent officer, Division is the General Manager or equivalent Officer and Subdivision is the Assistant Engineer or equivalent officer.
11. The e-Procurement software assigns roles for operation of the module for specific function. The terminologies used in the portal and their respective functions in the software are as follows.
 - 11.1 Application Administrator (NIC & State Procurement Cell)
 - i. Master Management
 - ii. Nodal Officer Creation
 - iii. Report Generation
 - iv. Transfer of Officer's login ID.
 - v. Blocking & unblocking of officer's and bidder's login ID.
 - 11.2 Nodal Officer (At organization level not below the Superintending Engineer or equivalent rank)
 - i. Creation of Users
 - ii. Role Assignment
 - iii. Report Generation
 - iv. Transfer of Officer's login ID.
 - v. Blocking & unblocking of officer's Login ID.
 - 11.3 Procurement Officer Publisher (Officer having tender inviting power at any level)

- i. Publishing of Tender
 - ii. Publishing of Corrigendum / addendum / cancellation of Tender
 - iii. Bid Clarification
 - iv. Uploading of Pre-Bid minutes.
 - v. Report generation.
- 11.4 Procurement Officer Administrator (Generally sub-ordinate officer to Officer Inviting Tender)
- i. Creation of Tender
 - ii. Creation of Corrigendum / addendum / cancellation of Tender
 - iii. Report generation.
- 11.5 Procurement Officer Opener (Generally sub-ordinate officer to Officer Inviting Tender)
- i. Opening of Bid
- 11.6 Procurement Officer Evaluator (Generally Sub-Ordinate Officer to Officer Inviting Tender)
- i. Evaluating Bid
- 11.7 Procurement Officer-Auditor (Procurement Officer Publisher and/or Accounts Officer / Finance Officer)
- i. To take up auditing

12. NOTICE INVITING BID (NIB) or INVITATION FOR BID (IFB):

- 12.1 The Notice Inviting Bids (NIB) and Bid documents etc., shall be in the Standard formats as applicable to conventional Bids and will be finalized / approved by the officers competent as in the case of conventional Bids.
- 12.2 The officers competent to publish NIB in case of conventional Bids will host the NIB in portal. Simultaneously, a notification should also be published in the newspapers, as per existing rules preferably, in the following format, to effect economy:-

Government of Odisha "e" procurement Notice	
Bid Identification No.-----	
1.	Name of the work:
2.	Estimated cost: Rs.
3.	Period of completion -----
4.	Date & Time of availability of bid document in the portal _____
5.	Last Date / Time for receipt of bids in the portal _____

6. Name and address of the O.I.T.:.....

Further details can be seen from the e-procurement portal "<https://tendersodisha.gov.in>"

12.3 The tender documents published by the Tender Inviting Officer (Procurement Officer Publisher) in the website <https://tendersodisha.gov.in> will appear in the "Latest Active Tender". The Bidders/ Guest Users can download the Bid documents only after the due date & time of sale. The publication of the tender will be for specific period of time till the last date of submission of bids as mentioned in the 'Notice inviting Bid' after which the same will be removed from the list of "Latest Active tenders".

13. ISSUE OF ADDENDA/ CORRIGENDA/ CANCELLATION NOTICE:

13.1 The Procurement Officer Publisher (Officer Inviting Tender) shall publish any addendum/ corrigendum/ cancellation of tender in the website <https://tendersodisha.gov.in>, notice board and through paper publication and such notice shall form part of the bidding documents.

13.2 The system generates a mail to those bidders who have already uploaded their tenders and those bidders if they wish can modify their tenders. The bidders are required to watch the website till last date and time of bid submission for any addendum/ corrigendum/ cancellation thereof. Tender Inviting Authority is not responsible for communication failure of system generated mail.

14. CREATION AND PUBLISHING OF BID:

14.1 All the volumes/documents shall be uploaded in the portal by the tender creating officer (Procurement Officer Administrator) and published by the Officer Inviting Tender (Procurement Officer Publisher) using their DSCs in appropriate format so that the document is not tampered with

14.2 The tender document comprise the notice inviting tender, bid document/ SBD, drawings in .pdf format and the schedule of quantities / BoQ in .xls format to be uploaded by the Officer Inviting Tender.

14.3 Procurement Officer Administrator creates tender by filling up the following forms:

i. BASIC DETAILS

ii. COVER CONTENT: The Procurement officer Administrator should briefly describe the name and type of documents to be uploaded by the bidder in the following format:

(a) For Single Cover/Packet:

SI No	Cover Type	Document Description	Type
1	Fee/ Prequal/ Technical/ Finance	Tender Cost, EMD, VAT, PAN, Contractor RC	.pdf
		Affidavits, undertakings and any other document as per SBD/DTCN.	.pdf
		BoQ	.xls

(b) For Two Cover/Packet:

SI No	Cover Type	Document Description	Type
1	Fee/ Prequal/ Technical	Tender Cost, EMD, VAT, PAN, Contractor RC	.pdf
		Affidavits, undertakings and any other document as per SBD/DTCN.	.pdf
2	Finance	BoQ	.xls
		Special condition if any specifically mentioned by Officer Inviting Tender	.pdf

- iii. TENDER DOCUMENT: The Procurement Officer Administrator should upload the NIT in .pdf format.
- iv. WORK ITEM DETAILS
- v. FEE DEATILS: The Procurement Officer Administrator should mention the cost of tender paper and EMD amount as laid down in DTCN/SBD.
- vi. CRITICAL DATES: The Procurement Officer Administrator should mention the critical dates of tender such as publishing date, document download start date & end date, seek clarification start date & end date (optional), bid submission start date & closing date, bid opening date as per DTCN/SBD.
- vii. BID OPENER SELECTION: The Procurement Officer creator can select two / three / four bid openers for a particular bid. If required the bid openers can also be selected within an organization from other procurement units (Circles /Divisions).
- viii. WORK ITEM DOCUMENTS: The Procurement Officer Administrator should upload the digitally signed tender document (SBD/DTCN) or any other addition document/drawings in .pdf format and Bill of Quantities in .xls format.
- ix. PUBLISHING OF TENDER: The Procurement Officer Publisher shall publish the tender using his/her DSC after detail scrutiny of the fields created and documents uploaded by the Procurement Officer Administrator. Procurement Officer Publisher can publish tenders for multiple procurement units using multiple DSCs procured for each post separately. After being relieved from the additional charges he has to surrender the additional DSCs to the Nodal Officer of the concerned organisation.

15. PARTICIPATION IN BID:

15.1 PORTAL REGISTRATION: The Contractor/Bidder intending to participate in the bid is required to register in the portal using his/her active personal/official e-mail ID as his/her Login ID and attach his/her valid Digital signature certificate (DSC) to his/her unique Login ID. He/She has to submit the relevant information as asked for about the firm/contractor. The portal registration of the bidder/firm is to be authenticated by the State Procurement Cell after verification of original valid certificates/documents such as (i) PAN and (ii) Registration Certificate (RC) / VAT Clearance Certificate (for procurement of goods) of the concerned bidder. The time period of validity in the portal is at par with validity of RC/ VAT Clearance. Any change of information by the bidder is to be re-authenticated by the State Procurement Cell. After successful authentication bidder can participate in the online bidding process.

15.1.1 Bidders participating through Joint Venture shall declare the authorised signatory through Memorandum of Understanding duly registered and enrol in the portal in the name and style of the Joint venture Company. It is mandatory that the DSC issued in the name of the authorised signatory is used in the portal.

15.1.2 Any third party/company/person under a service contract for operation of e-Procurement system in the State or his/their subsidiaries or their parent companies shall be ineligible to participate in the procurement process that are undertaken through the e-Procurement system irrespective of who operates the system.

15.2 LOGGING TO THE PORTAL: The Contractor/Bidder is required to type his/her *Login ID* and password. *The system will again ask to* select the DSC and confirm it with the password of DSC as a second stage authentication. For each login, a user's DSC will be validated against its date of validity and also against the Certificate Revocation List (CRL) of respective CAs stored in system database. The system checks the unique Login ID, password and DSC combination and authenticates the login process for use of portal.

15.3 DOWNLOADING OF BID: The bidder can download the tender of his choice and save it in his system and undertake the necessary preparatory work off-line and upload the completed tender at his convenience before the closing date and time of submission.

15.4 CLARIFICATION ON BID: The bidder may ask question related to tender online in the e-procurement portal using his/her DSC; provided the questions are raised within the period of seeking clarification as mentioned in tender call notice/Bid. The Officer Inviting the Bid / Procurement Officer-Publisher will clarify queries related to the tender.

15.5 PREPARATION OF BID

- 15.5.1 The bids may consist of general arrangements drawings or typical or any other drawings relevant to the work for which bid has been invited. Bidder may download these drawings and takeout print for detail study and preparation of his bid. Any other drawings and documents pertaining to the works available with the Officer Inviting The bid will be open for inspection by the bidders.
- 15.5.2 The Bidder shall go through the Bid carefully and list the documents those are asked for submission. He shall prepare all documents including cost of Bid Document, Bid Security, Declaration form, price bid etc. and store in the system.

15.6 PAYMENT OF EMD/BID SECURITY AND COST OF BID DOCUMENTS:

- 15.6.1 The Bidder shall furnish, as part of his Bid, a Bid security for the amount mentioned under NIT/Contract Data. The bidder shall scan all the written/printed pages of the bid security and up load the same in portable document format (PDF) to the system in designated place of the technical BID. Furnishing scanned copy of such documents is mandatory otherwise his/her bid shall be declared as non-responsive and liable for rejection.
- 15.6.2 The EMD or Bid Security payable along with the bid is 1% of the estimated contract value (ECV) or as mentioned in the bid document. The validity period of the EMD or Bid Security shall be as mentioned in the bid document. Any bid not accompanied by an acceptable Bid Security and not secured as indicated in the bid document shall be rejected as non-responsive. The bid security shall be retained till such time the successful bidder furnishes Initial Security Deposit (ISD) or Performance Security acceptable to the Officer Inviting the Bid. Failure of the successful Bidder to comply with the requirements shall constitute sufficient grounds for cancellation of the award and forfeiture of the Bid Security. The Bid security in the form of FD / BG shall be from a Nationalized Bank valid for a period of 45 days beyond the validity of the bid. Bid security in other form is acceptable if the bid documents provides for it.
- 15.6.3 The Fixed Deposit / Bank Guarantee or any other form as mentioned in detailed tender call notice in respect of Earnest Money Deposit / Bid Security and the Bank Draft in respect of cost of Bid are to be scanned and up loaded in portable document format (PDF) along with the bid.
- 15.6.4 The tender accepting authority will verify the originals of all the scanned documents of the successful lowest bidder only within 5 days of opening of the tender. In the eventuality of failure on the part of the lowest successful bidder to produce the original documents, he will be debarred in future

from participating in tender for 3 years and will be black listed by the competent authority. In such a situation, successful L-2 bidder will be required to produce his original documents for consideration of his tender at the negotiated rate equal to L1 bidder.

15.6.5 Contractor exempted from payment of EMD will be able to participate in the tender directly by uploading documentary evidences towards his eligibility for such exemption

15.6.6 Government of Odisha has been actively considering integrating e-payment gateway in to the portal for payment of Cost of Bid and Bid Security/ Earnest Money Deposit. The process of using e-payment gateway shall be issued separately after it is established.

16. SUBMISSION OF BID:

16.1 The bidder shall carefully go through the tender and prepare the required documents. The bid shall have a Technical Bid & a Financial Bid. The Technical bid generally consist of cost of Bid documents, EMD/ Bid Security, VAT, PAN / TIN, Registration Certificate, Affidavits, Profit Loss statement, Joint venture agreement, List of similar nature of works, work in hand, list of machineries, and any other information required by OIT. The Financial Bid shall consist of the Bill of Quantities (BOQ) and any other price related information/undertaking including rebates.

16.2 Bidders are to submit only the original BoQ (in .xls format) uploaded by Procurement Officer Publisher (Officer Inviting Tender) after entering the relevant fields without any alteration/ deletion / modification. Multiple BoQ submission by bidder shall lead to cancellation of bid. In case of item rate tender, bidders shall fill in their rates other than zero value in the specified cells without keeping it blank. In the percentage rate tender the bidder quoting zero percentage is valid and will be taken at par with the estimated rate of the work put to tender.

16.3 The bidder shall upload the scanned copy/copies of document in support of eligibility criteria and qualification information in prescribed format in Portable Document Format (PDF) to the portal in the designated locations of Technical Bid.

16.4 The bidder shall write his name in the space provided in the specified location in the Protected Bill of Quantities (BoQ) published by the Officer Inviting Tender. The bidder shall type rates in figure only in the rate column of respective item(s) without any blank cell in the rate column in case of item rate tender and type percentage excess or less up to two decimal place only in case of percentage rate tender.

- 16.5 The bidder shall log on to the portal with his/her DSC and move to the desired tender for up loading the documents in appropriate place one by one simultaneously checking the documents.
- 16.5.1 Bids cannot be submitted after due date and time. The bids once submitted can not be viewed, retrieved or corrected. The Bidder should ensure correctness of the bid prior to uploading and take print out of the system generated summary of submission to confirm successful uploading of bid. The bids can not be opened even by the OIT or the Procurement Officer Publisher/ opener before the due date and time of opening.
- 16.5.2 Each process in the e-procurement is time stamped and the system can detect the time of log in of each user including the Bidder.
- 16.5.3 The Bidder should ensure clarity/legibility of the document uploaded by him to the portal.
- 16.5.4 The system shall require all the mandatory forms and fields filled up by the contractor during the process of submission of the bid/tender.
- 16.5.5 The bidder should check the system generated confirmation statement on the status of the submission.
- 16.5.6 The Bidder should upload sufficiently ahead of the bid closure time to avoid traffic rush and failure in the network.
- 16.5.7 The Tender Inviting Officer is not responsible for any failure, malfunction or breakdown of the electronic system used during the e-procurement process.
- 16.5.8 The Bidder is required to upload documents related to his eligibility criteria and qualification information and Bill of Quantity duly filled in. It is not necessary for the part of the Bidder to up-load the drawings and the other Bid documents (after signing) while uploading his bid. It is assumed that the bidder has referred all the drawings and documents uploaded by the Officer Inviting the Bid.
- 16.5.9 The Bidder will not be able to submit his bid after expiry of the date and time of submission of bid (server time). The date and time of bid submission shall remain unaltered even if the specified date for the submission of bids declared as a holiday for the Officer Inviting the Bid.
- 16.6 **SIGNING OF BID:** The 'online bidder' shall digitally sign on all statements, documents, certificates uploaded by him, owning responsibility for their correctness / authenticity as per IT ACT 2000. If any of the information furnished by the bidder is found to be false / fabricated / bogus, his EMD/Bid Security shall stand forfeited & his registration in the portal shall be blocked and the bidder is liable to be blacklisted.

17. SECURITY OF BID SUBMISSION:

17.1 All bid uploaded by the Bidder to the portal will be encrypted.

17.2 The encrypted Bid can only be decrypted / opened by the authorised openers on or after the due date and time.

18. RESUBMISSION AND WITHDRAWAL OF BIDS:

18.1 Resubmission of bid by the bidders for any number of times before the final date and time of submission is allowed.

18.2 Resubmission of bid shall require uploading of all documents including price bid afresh.

18.3 If the bidder fails to submit his modified bids within the pre-defined time of receipt, the system shall consider only the last bid submitted.

18.4 The bidder should avoid submission of bid at the last moment to avoid system failure or malfunction of internet or traffic jam or power failure etc.

18.5 The Bidder can withdraw his bid before the closure date and time of receipt of the bid by uploading scanned copy of a letter addressing to the Procurement Officer Publisher (Officer Inviting Tender) citing reasons for withdrawal. The system shall not allow any withdrawal after expiry of the closure time of the bid.

19. OPENING OF THE BID:

19.1 Bid opening date and time is specified during tender creation or can be extended through corrigendum. Bids cannot be opened before the specified date & time.

19.2 All bid openers have to log-on to the portal to decrypt the bid submitted by the bidders.

19.3 The bidders & guest users can view the summary of opening of bids from any system. Contractors are not required to be present during the bid opening at the opening location if they so desire.

19.4 In the event of the specified date of bid opening being declared a holiday for the Officer Inviting the Bid, the bids will be opened at the appointed time on the next working day.

19.5 Combined bid security for more than one work is not acceptable.

19.6 The electronically submitted bids may be permitted to be opened by the predefined Bid opening officer from their new location if they are transferred after the issue of Notice Inviting Bid and before bid opening. Further, action on bid documents shall be taken by the new incumbent of the post.

19.7 In case of non-responsive tender the officer inviting tender should complete the e-Procurement process by uploading the official letter for cancelled / re-tender.

20. EVALUATION OF BIDS :

- 20.1 All the opened bids shall be downloaded and printed for taking up evaluation. The officer authorized to open the tender shall sign and number on each page of the documents downloaded and furnish a certificate that "the documents as available in the portal containing _____ nos. of pages".
- 20.2 The bidder may be asked in writing/ online (in their registered e-mail ids) to clarify on the uploaded documents provided in the Technical Bid, if necessary, with respect to any doubts or illegible documents. The Officer Inviting Tender may ask for any other document of historical nature during Technical Evaluation of the tender. Provided in all such cases, furnishing of any document in no way alters the Bidder's price bid. Non submission of legible documents may render the bid non-responsive. The authority inviting bid may reserve the right to accept any additional document.
- 20.3 The bidders will respond in not more than 7 days of issue of the clarification letter, failing which the bid of the bidder will be evaluated on its own merit.
- 20.4 The Technical evaluation of all the bids shall be carried out as per information furnished by Bidders.
- 20.5 The Procurement Officer-Evaluators; will evaluate bid and finalize list of responsive bidders.
- 20.6 The financial bids of the technically responsive bidders shall be opened on the due date of opening. The Procurement Officer-Openers shall log on to the system in sequence and open the financial bids.
- 20.6.1 The Financial Bid will be opened on the notified date & time in the presence of bidders or their authorised representative who wish to be present.
- 20.6.2 At the time of opening of "Financial Bid", bidders whose technical bids were found responsive will be opened.
- 20.6.3 The responsive bidders' name, bid prices, item wise rates, total amount of each item in case of item rate tender and percentage above or less in case of percentage rate tenders will be announced.
- 20.6.4 Procurement Officer-Openers shall sign on each page of the downloaded BoQ and the Comparative Statement and furnish a certificate to that respect.
- 20.6.5 Bidder can witness the principal activities and view the documents/summary reports for that particular work by logging on to the portal with his DSC from anywhere.
- 20.6.6 System provides an option to Procurement Officer Publisher for

reconsidering the rejected bid with the approval of concern Chief Engineer/
Head of Department.

21. NEGOTIATION OF BIDS:

21.1 For examination, evaluation, and comparison of bids, the officer inviting the bid may, at his discretion, ask the lowest bidder for clarification of his rates including reduction of rate on negotiation and breakdown of unit rates.

22. NOTIFICATION OF AWARD AND SIGNING OF AGREEMENT:

22.1 The Employer/Engineer-in-Charge shall notify acceptance of the work prior to expiry of the validity period by cable, telex or facsimile or e-mail confirmed by registered letter. This Letter of Acceptance will state the sum that the Engineer-in-Charge will pay the contractor in consideration of execution & completion of the Works by the contractor as prescribed by the contract & the amount of Performance Security and Additional Performance Security required to be furnished. The issue of the letter of Acceptance shall be treated as closure of the Bid process and commencement of the contract.

22.2 The Contractor after furnishing the required acceptable Performance Security & Additional Performance Security, "Letter to Proceed" or "Work Order" shall be issued by the Engineer-in-Charge with copy thereof to the Procurement Officer – Publisher. The Procurement Officer-Publisher shall up load the summary and declare the process as complete.

22.3 If the L-1 bidder does not turn up for agreement after finalization of the tender, then he shall be debarred from participation in bidding for three years and action will be taken to blacklist the contractor. Besides the consortium/ JV/ firm where such an agency/ firm already happens to be or is going to be a partner/member/proprietor, he/ they shall neither be allowed for participation in bidding for three years nor his/ their application will be considered for registration and action will be initiated to blacklist him/ them. In that case, the L-2 bidder, if fulfils other required criteria, would be called for drawing agreement for execution of work subject to condition that the L-2 bidder negotiates at par with the rate quoted by the L-1 bidder, otherwise the tender will be cancelled.

23. BLOCKING OF PORTAL REGISTRATION:

23.1 If the Registration Certificate of the Contractor is cancelled/ suspended by the registering authority/ blacklisted by the competent authority his portal registration shall be blocked automatically on receipt of information to that effect.

23.2 The portal registration blocked in the ground mentioned in the above Para-23.1 shall be unblocked automatically in receipt of revocation order of cancellation/ suspension/ blacklisting from the concerned authority.

23.3 The Officer Inviting Tender shall make due inquiry and issue show cause notice to the concerned contractor who in turn shall furnish his reply, if any, within a fortnight from the date of issue of show cause notice. Thereafter the Officer Inviting Tender is required to issue an intimation to the defaulting bidder about his unsatisfactory reply and recommend to the Chief Manager (Tech.) for blocking of portal registration within 10 days of intimation to the defaulting bidder regarding his unsatisfactory reply with intimation to the Registering Authority and concerned Chief Engineer/ Heads of Office if any of the following provisions are violated.

23.3.1 Fails to furnish original Technical/ Financial (Tender Paper Cost, EMD/Bid Security) instruments before the designated officer within the stipulated date and time.

23.3.2 Backs out from the bid on any day after the last date of receipt of tender till expiry of the bid validity period.

23.3.3 Fails to execute the agreement within the stipulated date.

23.3.4 If any of the information furnished by the bidder is found to be false/ fabricated/ bogus.

Accordingly the Officer Inviting Tender shall recommend to the Chief Manager (Tech.), State Procurement Cell, Odisha for blocking of portal registration of bidder and simultaneously action shall also be initiated by OFFICER INVITING TENDER for blacklisting as per Appendix- XXXIV of OPWD Code, Volume-II.

24. GUIDELINES FOR UNBLOCKING OF PORTAL REGISTRATION:

24.1 UNBLOCKING OF PORTAL REGISTRATION:

Unblocking of portal registration of a contractor shall be done by a Committee consisting of the following members.

EIC (Civil)-cum-CPO,	-	Chairman
Engineer-in-Chief (WR)	-	Member
Concerned Chief Engineer	-	Member
Sr. Manager (Finance), SPC	-	Member
Officer Inviting Tender	-	Member
Chief Manager (Technical), SPC	-	Convener

24.2 The Chief Manager (Tech), State Procurement Cell will be the convener and he will maintain all records for this purpose. The Committee shall meet not less than once in a month if required & shall consider the recommendation of the officer inviting tender for unblocking of portal registration. The quorum of the meeting will be four.

24.3 The minimum period of blocking of Portal Registration shall in no case be less than 90 days. After blocking of Portal Registration, the Contractor whose Portal

Registration has been blocked may file application to the concerned officer inviting tender showing sufficient ground for unblocking of his portal registration along with a Treasury Challan showing deposit of Rs. 10,000/- (Rupees ten thousand) only (non-refundable) under the head of accounts '0059 - Public Works' as processing fees. The officer inviting tender shall forward the application filed by the contractor to the Chief Manager (Tech), State Procurement Cell.

24.4 On receipt of recommendation from the concerned Chief Engineer along with the copy of challan as mentioned above, the Chief Manager (Tech) being the member Convener of the Committee shall place the case before the Committee for examination and taking a decision in this regard. After examination the Committee may recommend for unblocking of the portal registration of said contractor if the Committee is satisfied that the fault committed by the contractor is either unintentional or done for the first time.

24.5 After scrutiny by the State Procurement Cell if it is found that the portal registration of a contractor has been blocked for the 2nd time the Chief Manager (Tech), SPC may not consider his case to be placed before the Committee and may advise the concerned officer inviting tender to issue show cause notice to the contractor asking him to explain as to why his portal registration shall not remain blocked. On receipt of show cause reply from the contractor the officer inviting tender shall examine the same & if considered proper he may report to the Chief Manager (Tech), SPC along with his views furnishing the copy of the show cause reply for placement of the same before the Committee for taking a decision in respect of blocking/ unblocking. If the Committee found that the contractor is in habit of committing such fault again and again intentionally the committee may advise the concerned officer inviting tender to initiate proceeding for blacklisting as per the existing rule.

1. These amendments shall take effect from the date of issue of the order.
2. This amendment is an addition to the existing provision and will be placed below Appendix-IX to OPWD Col, Vol-II.
3. Accordingly Office Memorandum No.1027 dt.24.01.2009 stands modified.
4. This has been concurred in by the Finance Department vide their UOR No.3-WF-1 dt.04.01.2013.

Sd/19.07.2013

E.I.C-cum-Secretary to Govt.

ANNEXURE – II:

**Procedure for Electronic Receipt,
Accounting and Reporting of Cost of
Tender Paper and the agency will
submit Bid Security Declaration
along with the tender in absence of
EMD**

**Online Receipt of Tender Paper Cost & Earnest Money Deposit
through e-Procurement Portal
as per Works Department Letter No.17276/W Dt.06.12.2017**

**Government of Odisha
Works Department**

Office Memorandum

File No.07556900012016–17254/W Dt.05.12.2017

Sub: Electronic receipt, accounting and reporting of Cost of Tender Paper and Earnest Money Deposit on submission of bids.

1. The State Government have formulated rules and procedures for Electronic receipt, accounting and reporting of the receipt of Cost of Tender Paper and Earnest Money Deposit on submission of bids through the e-procurement portal of Government of Odisha i.e. "<https://tendersodisha.gov.in>".
2. Electronic receipt of cost of tender paper has been successfully tested through SBI payment gateway. Now it has been decided to introduce electronic receipt of **Cost of Tender Paper and Earnest Money Deposit on submission of bids** through payment gateway of designated banks such as **SBI/ICICI Bank/HDFC Bank** for all Government Departments, State PSUs, Statutory Corporations, Autonomous Bodies and Local Bodies etc. in phases (ANNEXURE-1). The process outline as well as accounting and reporting structure are indicated below :
 - a) It will be carried out through a single banking transaction by the bidder for multiple payments like **Cost of Tender Paper and Earnest Money Deposit on submission of bids**.
 - b) Various payment modes like **Internet banking/ NEFT/RTGS** of Designated Banks and their Aggregator Banks as well can be accessed by the intending bidders.
 - c) Reporting and accounting of the **e-receipts** will be made from a single source.
 - d) Credit of receipts into the Government accounts and to the designated Bank account of the participating entities indicated in Para 2 above would be faster.
3. Only those bidders who successfully remit their **Cost of Tender Paper and Earnest Money Deposit on submission of bids would be eligible to** participate in the tender/bid process. The bidders with pending or failure payment status shall not be able to submit their bid. Tender inviting authority, State Procurement Cell, NIC, the designated Banks shall not be held responsible for such pendency or failure.

4. Banking arrangement:

- a) Designated Banks (**SBI/ICICI Bank/HDFC Bank**) payment gateway are being integrated with e-Procurement portal of Government of Odisha (<https://tendersodisha.gov.in>)
- b) The Designated Banks participating in **Electronic receipt, accounting and reporting of Cost of Tender Paper and Earnest Money Deposit on submission of bids** will nominate a **Focal Point Branch** called e-FPB, who is authorized to collect and collate all e-Receipts. Each such branch will act as the Receiving branch and Focal Point Branch notwithstanding the fact that the bidder might have debited his account in any of the bank's branches while making payment.

5. Procedures of bid submission using electronic payment of tender paper cost and EMD by bidder:

- a) **Log on to e-Procurement Portal:** The bidders have to log onto the Odisha e-Procurement portal (<https://tendersodisha.gov.in>) using his/her digital signature certificate and then search and then select the required active tender from the "Search Active Tender" option. Now, submit button can be clicked against the selected tender so that it comes to the "My Tenders" section.
- b) **Uploading of Prequalification/Technical/Financial bid:** The bidders have to upload the required Prequalification /Technical/Financial bid, as mentioned in the bidding document and in line with Works Department office memorandum no.7885, dt.23.07.2013.
- c) **Electronic payment of tender paper cost and EMD:** Then the bidders have to select and submit the bank name as available in the payment options
 - i. A bidder shall make electronic payment using his/her **internet banking** enabled account with designated Banks or their aggregator banks.
 - ii. A bidder having account in other Banks can make payment using **NEFT/RTGS** facility of designated Banks.
 - Online NEFT/RTGS payment using internet banking of the bank in which the bidder holds his account, by adding the account number as mentioned in the challan as an interbank beneficiary.
- d) **Bid submission:** Only after receipt of intimation at the e-Procurement portal regarding successful transaction by bidder the system will activate the 'Freeze Bid Submission' button to conclude the bid submission process.
- e) **System generated acknowledgement receipt for successful bid submission:** System will generate an acknowledgement receipt for successful bid submission. The bidder should make a note of '**Bid ID**' generated in the acknowledgement receipt for tracking their bid status.

6. Settlement of Cost of Tender Paper;

- a) **Cost of Tender Paper:** In respect of Government receipts on account of **Cost of Tender Paper**, the e-Procurement portal shall generate a MIS for the State Procurement Cell (SPC). The MIS will contain an abstract of the cost of

tender paper collected with reference to **Bid Identification Number**. The State Procurement Cell shall generate Bank-wise-head-wise challans separately for **Cost of Tender Paper** and instruct the designated Banks to remit the money to the State Government account under different heads. In respect of the cost of tender paper received through the e-procurement portal, the remittance to the Cyber Treasury account will be made to the Head of Account 0075-Misc, General Services-800-Other Receipts -0097-Misc. Receipts-02237-Cost of Tender Paper.

- b) For the time being, the State Procurement Cell (SPC) will use over the counter payment facility of the Odisha Treasury portal. Thereafter, remittance through NEFT & RTGS will be facilitated through the Odisha Treasury portal.
- c) Similarly, in case of State PSUs, Statutory Corporations, Autonomous Bodies and Local Bodies etc., **Cost of Tender Paper**, the e-Procurement portal shall generate a MIS for the State Procurement Cell (SPC). The MIS will contain an abstract of the cost of tender paper collected with reference to **Bid Identification Number**. The State Procurement Cell shall generate Bank-wise list of challans and instruct the designated Banks to remit the money through the Odisha Treasury portal. The cost of tender papers will be credited to the registered Bank account of the concerned State PSUs, Statutory Corporations, Autonomous Bodies and Local Bodies etc.
- d) Bank will refund (in case the Tender Inviting Authority (TIA) issues such instructions) the tender fee, EMD to the bidder, in case the tender is cancelled before opening of Bid as per direction received from TIA through e-procurement system.
- e) Back-end Transaction Matrix of Electronic receipt of Cost of Tender Paper and Earnest Money Deposit on submission of bids is enclosed in the Annexure.

7. Settlement of Earnest Money Deposit on submission of bids:

- a) The Bank will remit the **Earnest Money Deposit on submission/cancellation of bids** to respective bidders accounts as per direction received from TIA through e-procurement system.

8. Forfeiture of EMD :

Forfeiture of **Earnest Money Deposit on submission of bid** of defaulting bidder is occasioned for various reasons.

- a) In case the **Earnest Money Deposit on submission of bid** is forfeited, the e-Procurement portal will direct the Bank to transfer the EMD value from the Pooling Account of SPC to the registered account of the tender inviting authority.
- b) The Tender inviting authorities of the Government Departments will deposit the forfeited **Earnest Money Deposit on submission of bid**, in the State Government Treasury under the appropriate head (8782-Cash Remittances and Adjustments between the officers rendering accounts to the same Accounts Officer-102-P.W.Remittances-1683-Remittances-91028-Remittances into

Treasury) after taking the amount as a revenue receipt in their Cash Book under the head 0075-Misc. General Services-00-101 -Unclaimed Deposits-0097-Misc, Receipts-02080-Misc. Deposits and submit the detail account to DAG (Puri) as a deposit of the Division.

- c) By clicking submit button, system will initiate the forfeiture of EMD. System will not allow the evaluator to edit the initiation after clicking the submit button. Forfeiture option can be carried out in phased manner like one bidder at a time.

9. Role of the Banks:

- a) Make necessary provision / customizations at their end to enable the provision for online payments / refunds as per this document.
- b) Provide necessary real-time message to bidders regarding successful or unsuccessful transactions during online payment processes and redirect them to e-Procurement website with necessary transaction reference details enabling them to submit their bids.
- c) The bank shall ensure transfer of funds from the pooling account to the Government Head/current account of PSUs/ULBs within the next bank working day as per the directions generated from e-Procurement portal.
- d) Bank should provide timely reports and reference details to NIC enabling them to carry out their role as stated below.
- e) Refund of amount to bidders as per the XML file provided by e-Procurement system on the next bank working day from the date of generation of the XML file and also provide a confirmation to NIC on the same.

10. Role of State Procurement Cell:

- a) Communicate requirements of Government departments/ State PSUs/ Autonomous Bodies/ ULBs online payment requirements to National Informatics Centre / the authorised Banks for mapping/ customization.
- b) In every working day, the State Procurement Cell shall generate MIS from the e-Procurement portal to ascertain the tender paper cost received in the e-Tendering process separately bank-wise for the Government Department and the PSUs/ULBs. The SPC shall generate bank-wise separate online challans from the Odisha Treasury portal and make the remittance through over the counter facility or NEFT/RTGS (as and when this functionality is available in Treasury portal) and issue instruction to the bank for remittance of the receipt to the State Government account.
- c) The State Procurement Cell shall be responsible for providing challan details and MIS in respect of the remittance towards tender paper cost to the Tender inviting authorities for their record.
- d) State Procurement Cell shall monitor the progress of e-Tendering by different Government departments / State PSUs/ Autonomous Bodies / ULBs through an MIS. State Procurement Cell shall monitor and send monthly progress reports to the Government.
- e) The e-Procurement system will generate a consolidated refund & settlement XML file as an end of the day activity.

- f) e-procurement system will provide a web service for payment gateway (PG) provider to pull the encrypted refund and settlement details in XML file against a day.
- g) Similarly, payment gateway (PG) provider will provide a web service to pull the refund and settlement status against a day
- h) e-procurement system will update the status accordingly for reconciliation report.

11. Role of National Informatics Centre :

- a) Customize e-Procurement software and web-pages of Government of Odisha (<https://tendersodisha.gov.in>) to enable the provision for electronic payment.
- b) The NIC, Odisha will modify / rectify the errors in electronic data relating to the Chart of Account.
- c) NIC will provide an interface to organisations to download the electronic receipt data.
- d) Enable automatic generation of daily XML files from e-Procurement system and ensure delivery of the same to the authorised Banks for enabling automatic refund/settlement of funds.
- e) NIC shall enable the e-Procurement portal to generate MIS as required for the State Procurement Cell in order to make remittance of the tender paper cost to the State Government account using the Odisha Treasury portal.

12. Role of Cyber Treasury :

- a) The cost of the tender paper deposited by the SPC using the Odisha Treasury Portal which will be accounted for by the Cyber Treasury and it shall submit the accounts to A.G (O) as per the established process.
- b) The Cyber Treasury will provide MIS as required to the SPC for the purpose of accounting and reconciliation of the electronic remittances made to the State Government account.

13. Redressal of Public grievances :

- a) The State Procurement Cell, Odisha, National Informatics Centre, Odisha and the e-FPB will have an effective procedure for dealing with, public complaint for e-Receipt related matters. In case, any mistake is detected by any of the stakeholders in reporting of receipt of tender paper cost and EMD, either suo moto or on being brought to its notice, the State Procurement Cell, Odisha, National Informatics Centre, Odisha unit, Cyber Treasury and the bank will promptly take steps for rectification. The e-Focal Point Branch of the participating Banks, National Informatics Centre, Odisha and the State Procurement Cell, Odisha will notify the contact number and address of the Help Desk for resolution of any dispute regarding e-Receipt.

14. Applicability and modification of existing rules / orders:

The modalities prescribed in this Office Memorandum for downloading of tender paper, submission and rejection of bid, acceptance of Bids as well as refund and forfeiture of earnest deposit will be applicable for electronic submission of bids through e-procurement portal. Existing provisions regulating cost of tender paper,

earnest money deposit in OPWD Code and OGFR would stand modified to the extent prescribed.

15. These arrangements would be made effective after signing of MoU between the designated Banks and the State Procurement Cell, firming up of Banking arrangements and technical integration between designated Bank and e-Procurement Portal.
1. This shall take effect from the date of issue of this Office Memorandum.
2. Accordingly, relevant existing codal/ contractual provision exist vide Office Memorandum No.6785/W Dt.09.05.2017 of Works Department stands modified to the above extent.
3. This has been concurred in by the Finance Department vide their UOR No.-39-WF-I Dt.09.11.2017.

Sd/05.12.2017
E.I.C-cum-Secretary to Govt.

[For any Technical related queries please call at Help desk numbers of State Procurement Cell (SPC), Govt. of Odisha – 1800 3456 765, 0674-2530998, 2530996]

ANNEXURE-I of Appendix - IV

Back-end Transaction Matrix of Electronic receipt and remittance of Cost of Tender Paper and Earnest Money Deposit on submission of bids.

	Cost of Tender Paper on submission of bids	Earnest Money Deposit on submission of bids
Government Departments	<p>I. The payment towards the cost of Tender Paper, in case Government Departments, shall be collected in separate Pooling accounts opened in Focal Point Branch called e-FPB of respective designated banks [as stated in Para 2] at Bhubaneswar on T+1_day.</p> <p>II. With reference to the Notice Inviting Tender/ Bid Identification Number, the amount so realized is to be remitted to Government Account under the Head Of Account 0075-Misc. General Services-800-Other Receipts-0097-Misc. Receipts-02237-Cost of Tender Paper through Odisha Treasury Portal after opening of the bid.</p>	<p>I. In case of tenders of Government Departments, amount towards Earnest Money Deposit on submission of bids shall be collected in a pooling account opened for this purpose at Focal Point Branch called e-FPB of respective designated banks at Bhubaneswar and the banks will remit the amount to respective bidder's account within two working days on receipt of instruction from TIA through refund and settlement of e-procurement system.</p> <p>II. In case of forfeiture of Earnest Money Deposit on submission of bids, the e- Procurement portal will direct the Bank to transfer the EMD value from the Pooling Account of SPC to the registered account of the tender inviting authority within two working days of receipt of instruction from TIA.</p>
State PSUs Statutory Corporations, Autonomous Bodies and Local Bodies.	<p>I. In case of State PSUs, Statutory corporations, Autonomous Bodies and Local Bodies etc. the amount towards Cost of Tender Paper, on submission of bids shall be collected in separated pooling accounts opened in Focal Point Branch called e-FPB of respective designated Banks at Bhubaneswar on T+1 days.</p> <p>II. The Paper cost will be transferred to the respective current accounts of concerned State PSUs, Statutory Corporation, Autonomous Bodies and Local Bodies etc. after opening of bid.</p>	<p>I. Amount towards EMD on submission of bids shall be collected in a separate pooling account of Focal Point Branch called e-FPB of respective designated banks at Bhubaneswar and the banks will remit the amount to respective bidder's account on receipt of instruction from TIA through refund and settlement of e-procurement system within two working days from receipt of such instruction.</p> <p>II. In case of forfeiture of Earnest Money deposit on submission of bids, the e- Procurement portal will direct the Bank to transfer the EMD value from the Pooling Account of SPC to the registered account of the tender inviting authority within two working days of receipt of instruction from TIA.</p>

ANNEXURE – III: Drawings

S. No.	Drawing No.	Description	Total Number of Drawings
1.	TD/HSC/Z-1/01	Typical Detail of Pipe Trench, Bedding and Chamber	1
2.	TD/HSC/Z-1/02	Sewer Layout Zone-1, Cuttack	1
3.	TD/HSC/Z-2/03	Sewer Layout Zone-2, Cuttack	1
4.	TD/HSC/Z-3A/04	Sewer Layout Zone-3A, Cuttack	1
5.	TD/HSC/Z-3B/05	Sewer Layout Zone-3B, Cuttack	1
6.	TD/HSC/Z-3C/06	Sewer Layout Zone-3C, Cuttack	1
7.	TD/HSC/Z-3D/07	Sewer Layout Zone-3D, Cuttack	1
8.	TD/HSC/Z-5A/08	Sewer Layout Zone-5A, Cuttack	1
9.	TD/HSC/Z-5B/09	Sewer Layout Zone-5B, Cuttack	1
10.	TD/HSC/Z-6A/10	Sewer Layout Zone-6A, Cuttack	1
11.	TD/HSC/Z-6B/11	Sewer Layout Zone-6B, Cuttack	1
12.	TD/HSC/Z-6C/12	Sewer Layout Zone-6C, Cuttack	1
13.	TD/HSC/Z-6D/13	Sewer Layout Zone-6D, Cuttack	1
14.	TD/HSC/Z-7A/14	Sewer Layout Zone-7A, Cuttack	1
15.	TD/HSC/Z-7B/15	Sewer Layout Zone-7B, Cuttack	1
TOTAL DRAWINGS IN ANNEXURE-III			15

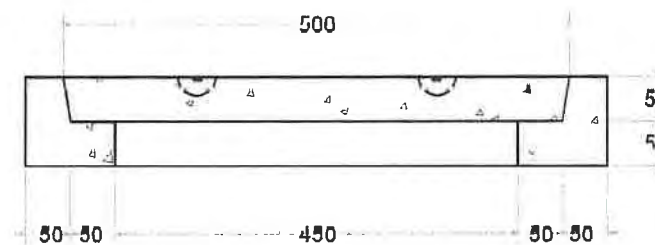
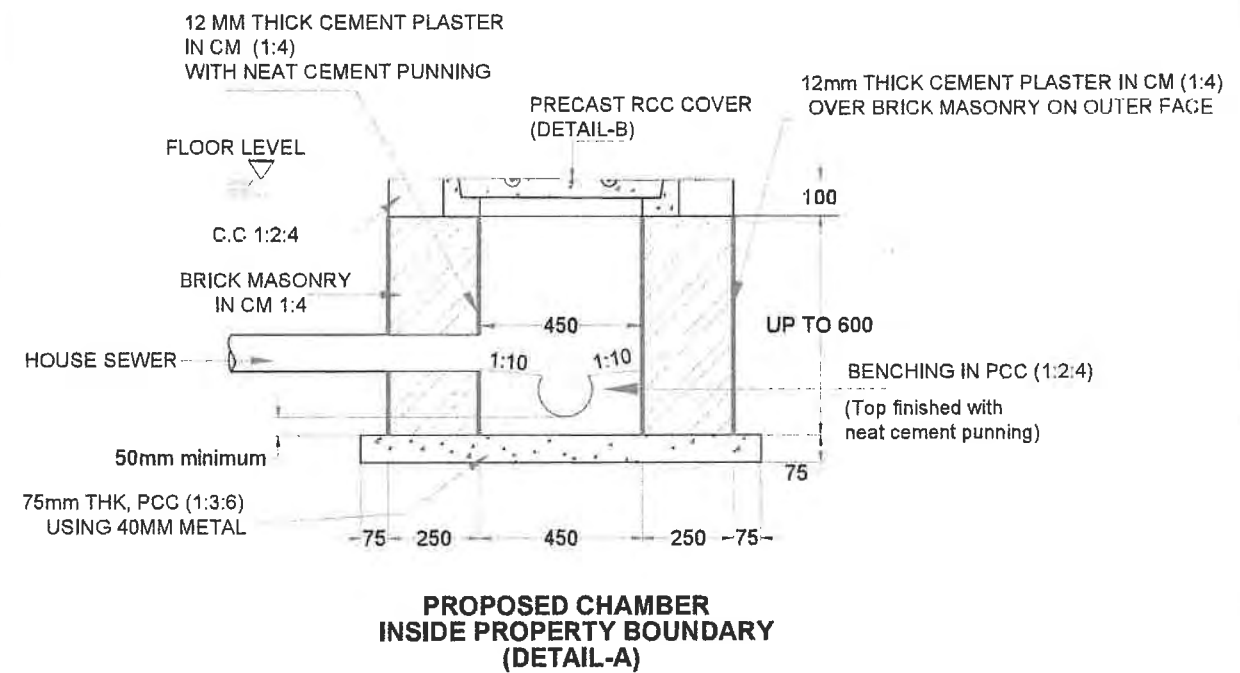
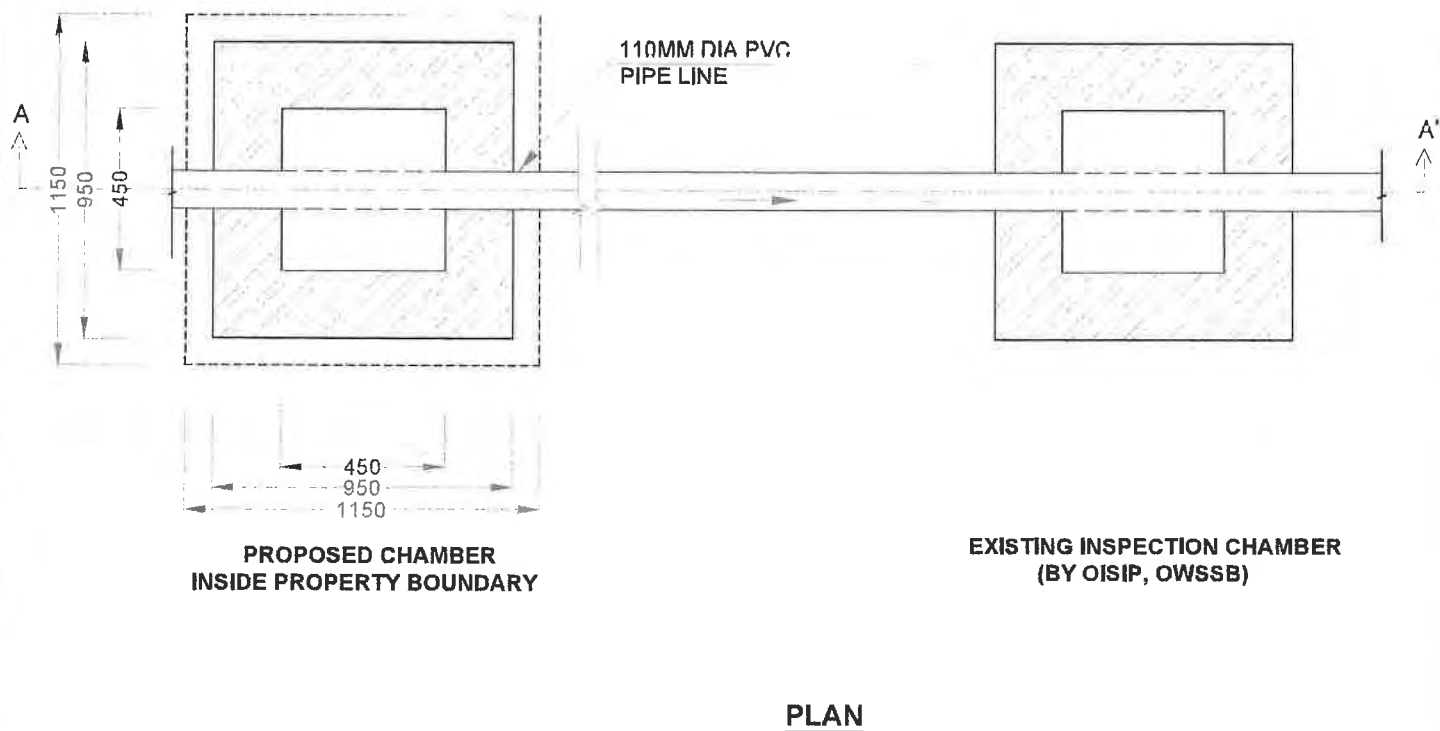
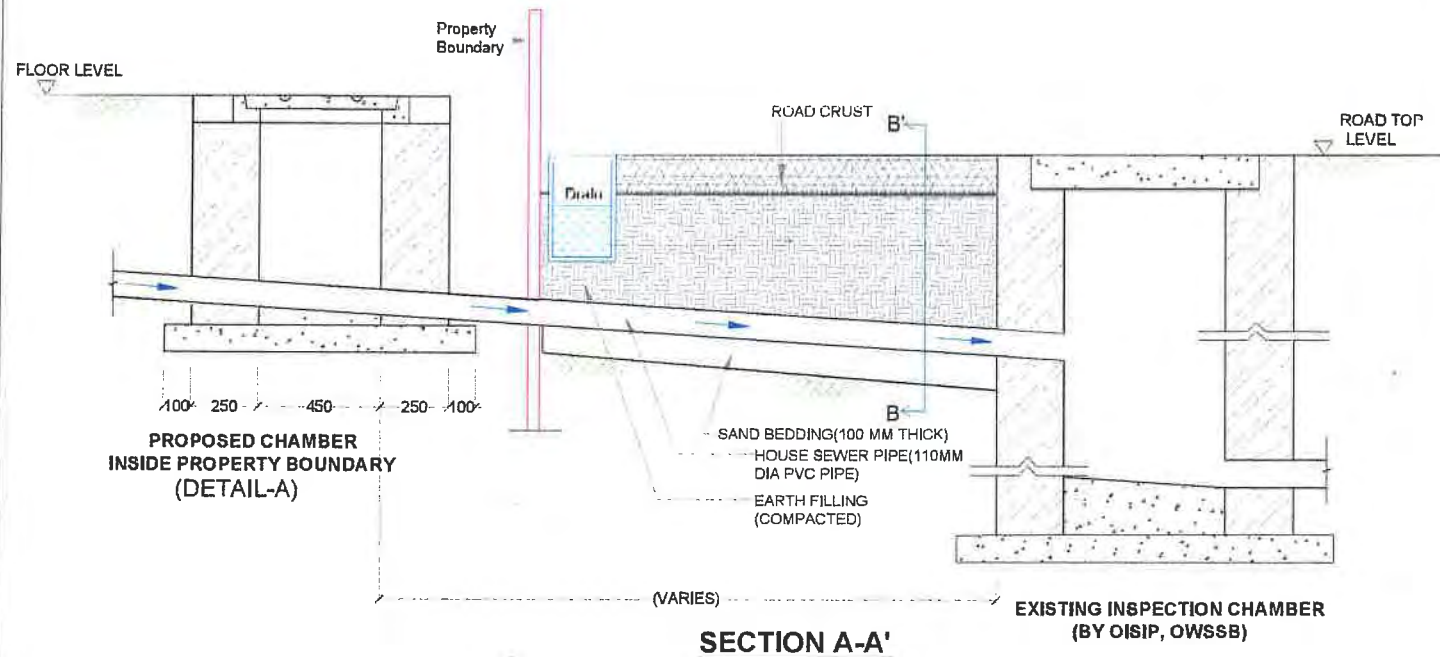

PRECAST RCC COVER AND FRAME, SQUARE (450X450) OF GRADE (LD 2.5) AS PER IS:12592 (DETAIL-B)

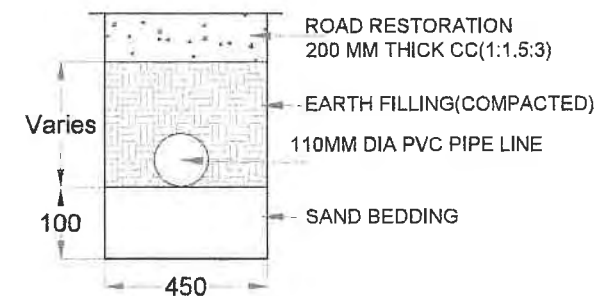

PIPE TRENCH (SECTION B-B')

TENDER DRAWING FOR HOUSE SEWER CONNECTION

Rev	Revision Description	Drawn	Date	Checked	Auth'd

Project
JICA Assisted Odisha Integrated Sanitation Improvement Project

Client
ODISHA WATER SUPPLY & SEWERAGE BOARD

Consultant
ENGINEERING & PROJECT MANAGEMENT CONSULTANTS
Tetra Tech Inc. and Egis becom International
Plot No. - E-61, Infocity, Patia, Bhubaneswar - 751013, Odisha
Phone : 0674 - 6603333
ODISHA, Fax : 0674-6603311
Plot No. - 2C/189, Sector-9, CDA, Near Jugal Kishore park, Cuttack - 753014, Odisha
Phone : 0671 - 2359904
Fax : 0671- 2309905

TYPICAL DETAIL OF PIPE TRENCH BEDDING AND CHAMBER

Original Scale	Drawn	Checked	Authorised	S.SIZE
NTS	Date 15/02/2022	Date	Date	A3
Drawing Number	Ref. Code	Sheet No	Rev	
TD/HSC/TD/01	OISIP/02 - C - D		0	

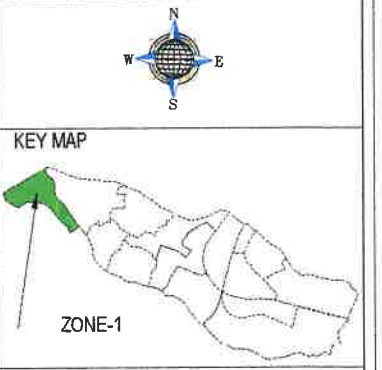
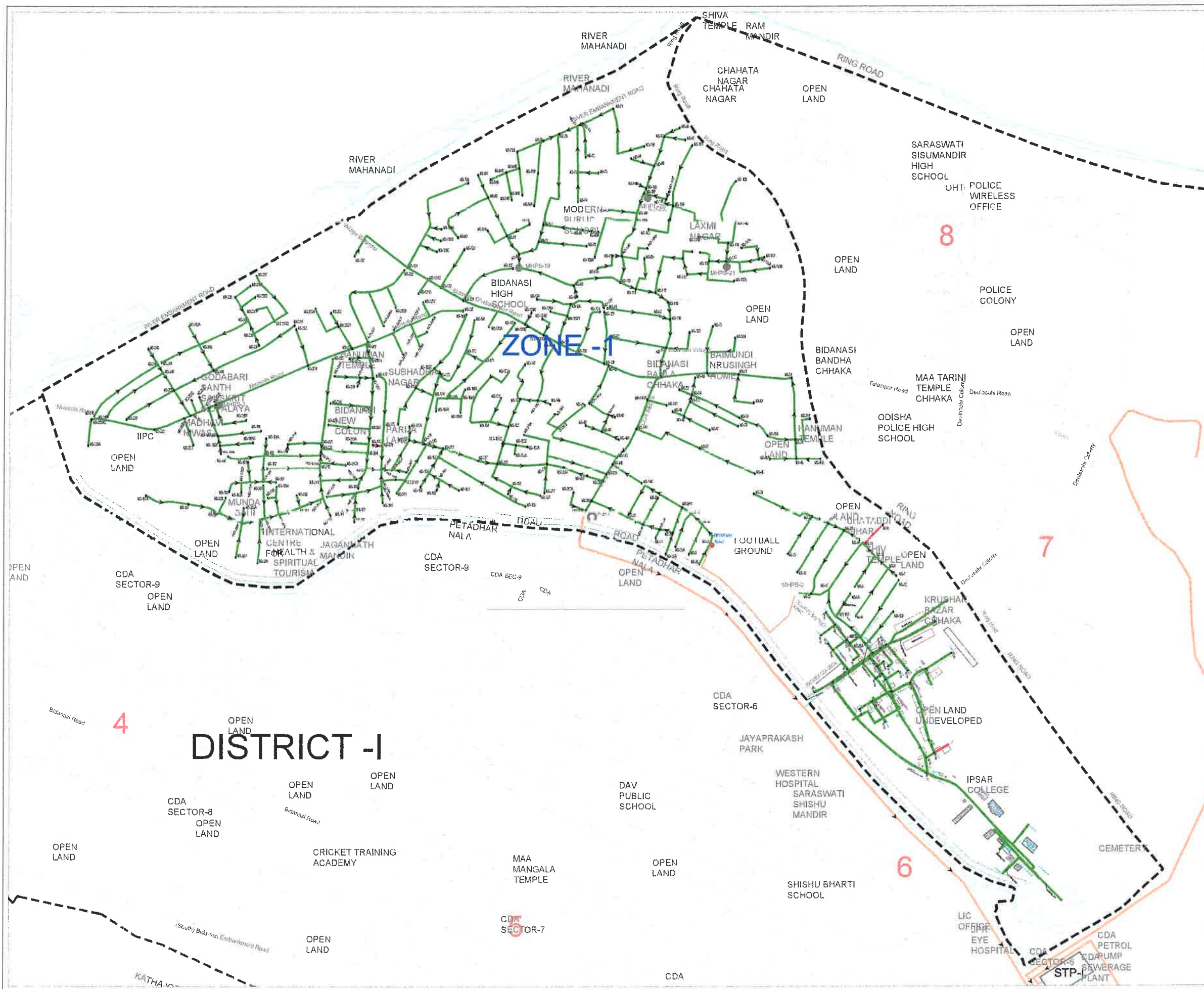

Area of Zone - 1 = 1.95 Sqkm

TENDER DRAWING FOR HOUSE SEWER CONNECTION

LEGENDS

- ROAD
- SEWER PIPE LINE
- RISING MAIN
- ZONE BOUNDARY
- WARD BOUNDARY
- WARD NOS W-16

Rev	Revision Description	Drawn	Date	Checked	Auth'd

Project: **JICA Assisted Odisha Integrated Sanitation Improvement Project**

Client: **ODISHA WATER SUPPLY & SEWERAGE BOARD**

Consultant: **ENGINEERING & PROJECT MANAGEMENT CONSULTANTS**
 (Consortium of Tokyo Engineering Consultants Co., Ltd., Tetra Tech Inc., and Eylee Incom International)

Title: **SEWER LAYOUT ZONE-1, CUTTACK**

Original Scale	Drawn	Checked	Authorised	S. NO
NTS	Date: 05/04/2022	Date:	Date:	A3
Drawing Number	Ref. Code	Sheet No	Rev	
TD/HSCZ-1/02	08MPN2 - C - D		0	

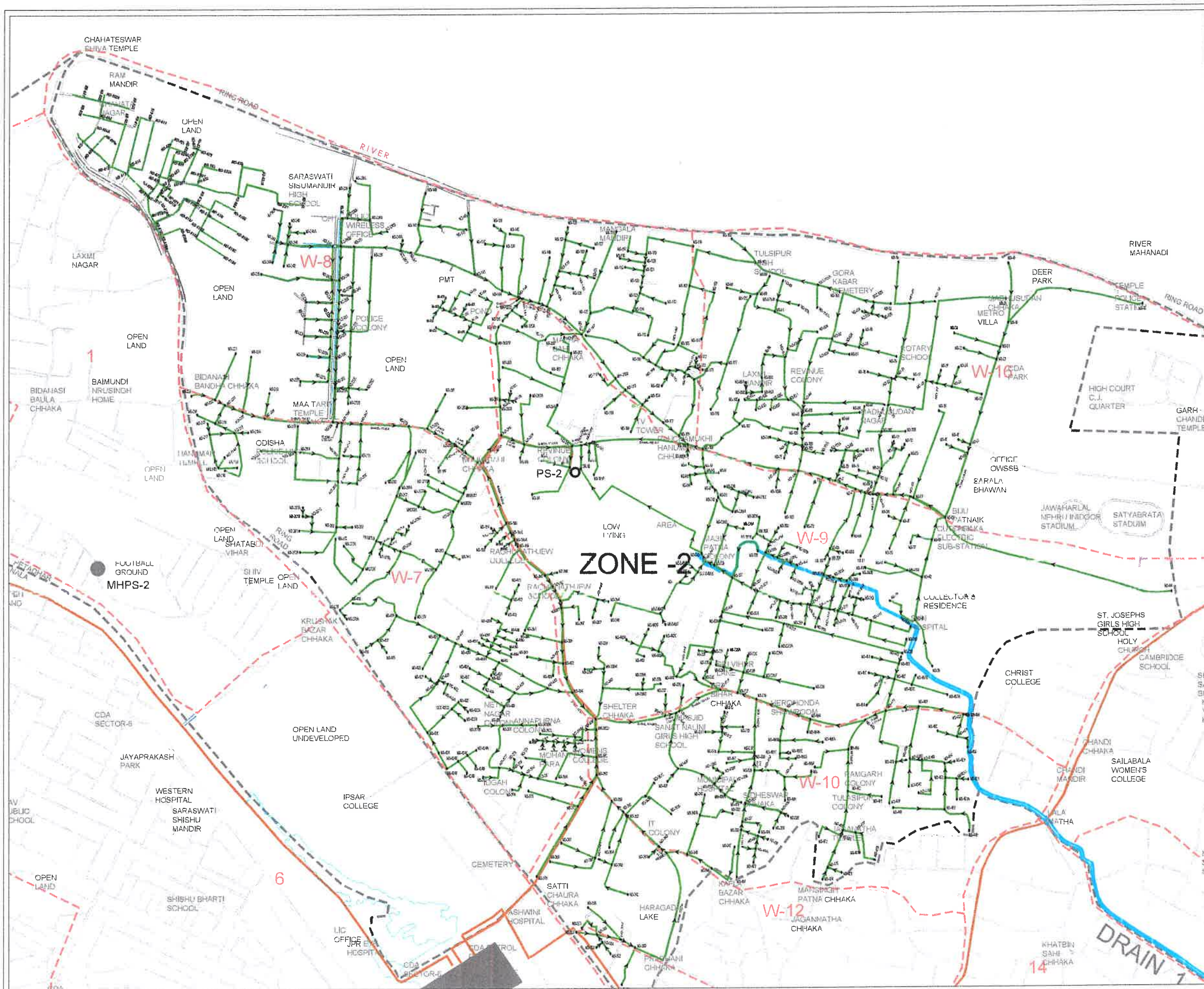

KEY MAP

ZONE-2

Area of Zone - 2 = 3.23 Sqkm

TENDER DRAWING FOR HOUSE SEWER CONNECTION

LEGEND

- ROAD
- SEWER PIPE LINE
- RISING MAIN
- ZONE BOUNDARY
- WARD BOUNDARY
- WARD NOS

Rev	Revision Description	Drawn	Date	Check'd	Auth'd

Project
JICA Assisted
Odisha Integrated Sanitation
Improvement Project

Client

ODISHA WATER SUPPLY & SEWERAGE BOARD

Consultant
ENGINEERING & PROJECT MANAGEMENT CONSULTANTS

 (Consortium of Tokyo Engineering Consultants Co., Ltd., Tatra Tech Inc. and Egis Techno International)

Plot No. 20195, Sector-4, CDA, near Jugal Mahara park, Cuttack - 753014, Odisha
 Phone : 0674-4863333
 Odisha : 0674-2506852
 Fax : 0674-6803311

SEWER LAYOUT ZONE-2, CUTTACK

Original Scale	Drawn	Checked	Authorised	Sheet No.
NTS	Date: 05/04/2022	Date:	Date:	A3

Drawing Number	Ref. Code	Sheet No.	Rev
TDR/HC/Z-2/03	DRP/01 - C - 5		0

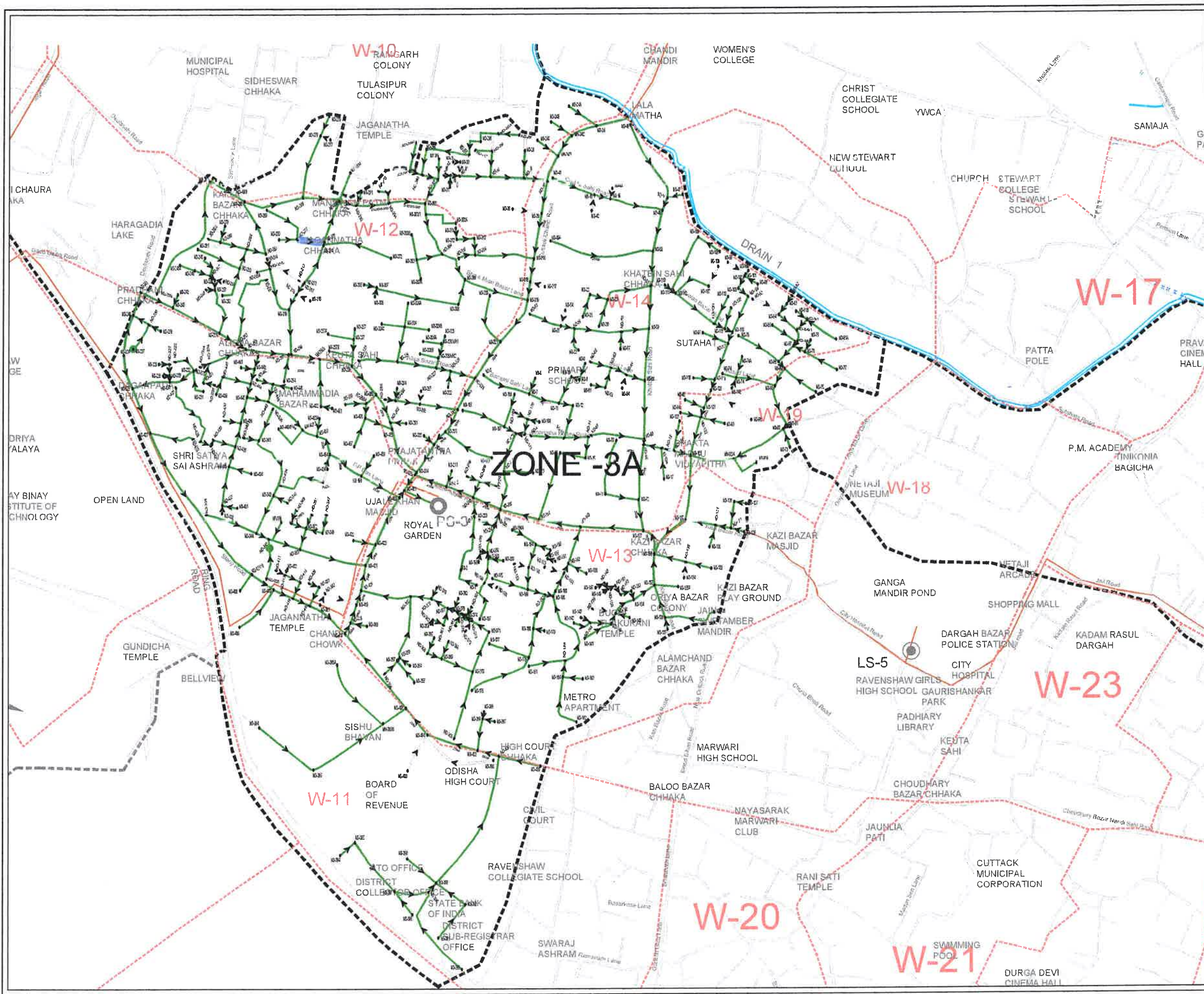

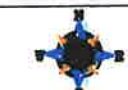

KEY MAP



Area of Zone - 3A = 1.39 Sqkm

TENDER DRAWING FOR HOUSE SEWER CONNECTION

LEGENDS

- ROAD
- SEWER PIPE LINE
- RISING MAIN
- ZONE BOUNDARY
- WARD BOUNDARY
- WARD NOS W-16

Rev	Revision Description	Drawn	Date	Checked	Auth'd

Project
JICA Assisted Odisha Integrated Sanitation Improvement Project

Client
ODISHA WATER SUPPLY & SEWERAGE BOARD

Consultant
ENGINEERING & PROJECT MANAGEMENT CONSULTANTS
 Consortium of Tokyo Engineering Consultants Co., Ltd., Tetra Tech Inc. and Egis Access International

CONSORTIUM
 Plot No. 10-4C/1586, Sector-10, CDA, Marumagar, Cuttack - 753014, Odisha
 Phone : 0674-2803333
 ODRINK, Fax : 0674-2803311

Title
SEWER LAYOUT ZONE-3A,CUTTACK

Original Scale	Drawn	Checked	Authorised	S.AZS
NTS	Date: 05/04/2022	Date:	Date:	A3
Drawing Number	Ref. Code	Sheet No	Rev	
TD/MS/CZ-3A/04	OMIP/02 - C - 6		0	

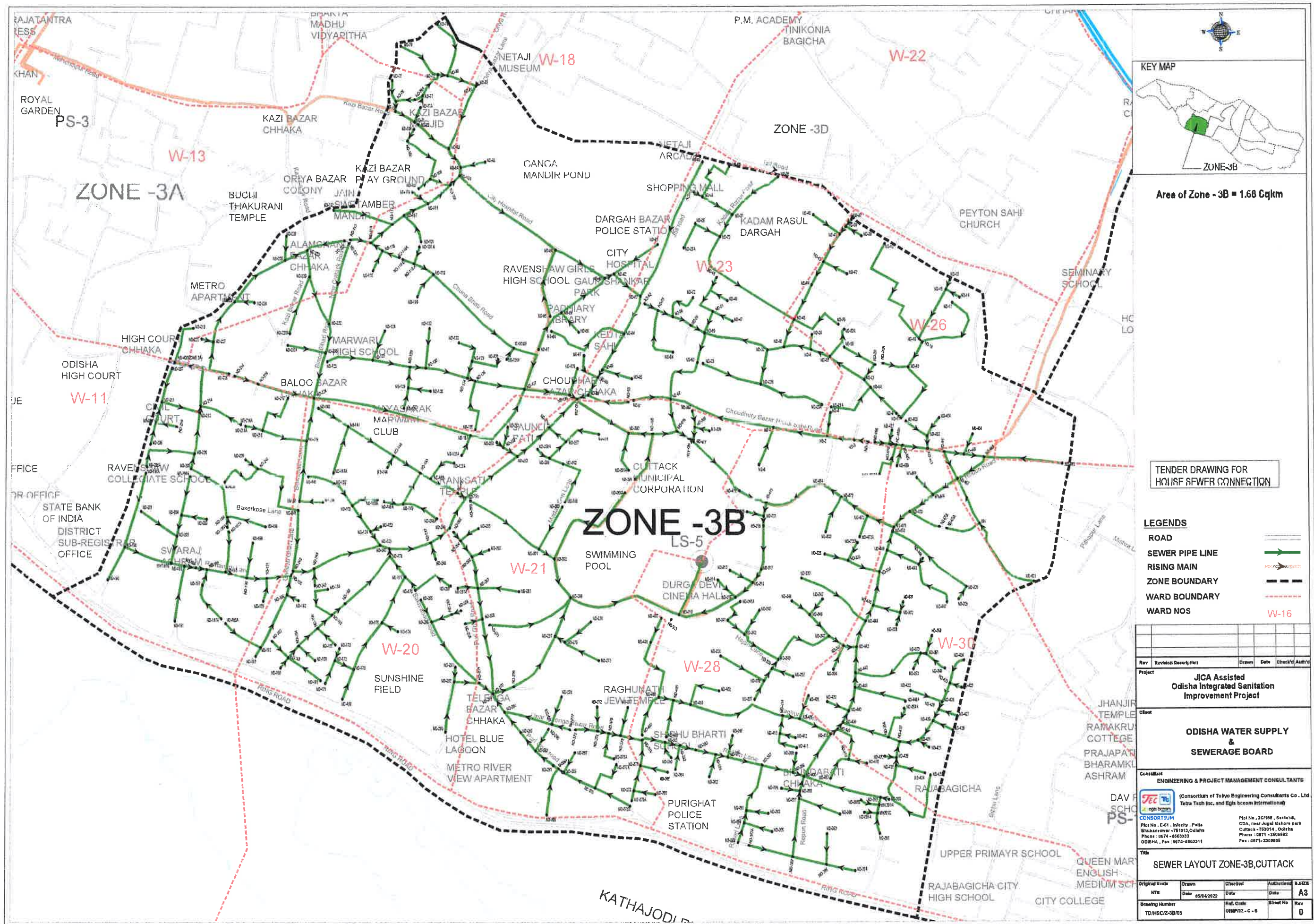

Area of Zone - 3B = 1.68 Cqkm

TENDER DRAWING FOR HOI/SF SEWER CONNECTION

LEGENDS

ROAD	
SEWER PIPE LINE	
RISING MAIN	
ZONE BOUNDARY	
WARD BOUNDARY	
WARD NOS	

Rev	Revision Description	Drawn	Date	Check'd	Auth'd

Project: **JICA Assisted Odisha Integrated Sanitation Improvement Project**

Client: **ODISHA WATER SUPPLY & SEWERAGE BOARD**

Consultant: **ENGINEERING & PROJECT MANAGEMENT CONSULTANTS**

(Consortium of Tokyo Engineering Consultants Co., Ltd., Tetra Tech Inc. and Egis Inc. International)

Plot No. 2C/168, Sector-4, CDA, near Jugal Kishore para Cuttack - 753014, Odisha
 Phone : 0674 - 660333 Phone : 0671 - 250482
 ODISHA, Fax : 0674-660311 Fax : 0671-250805

Title: **SEWER LAYOUT ZONE-3B,CUTTACK**

Original Code	Drawn	Checked	Authorised	Scale
MTS	Date: 05/02/2022	Date:	Date:	A3

Drawing Number	Ref. Code	Sheet No	Rev
TD/HSC/Z-3B/05	08AP02 - C - 6		0

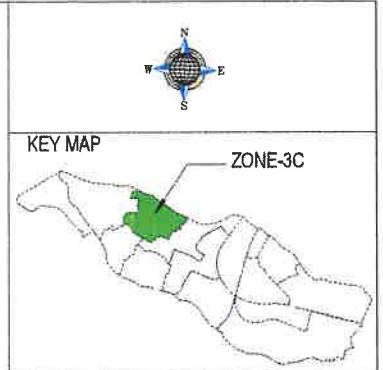
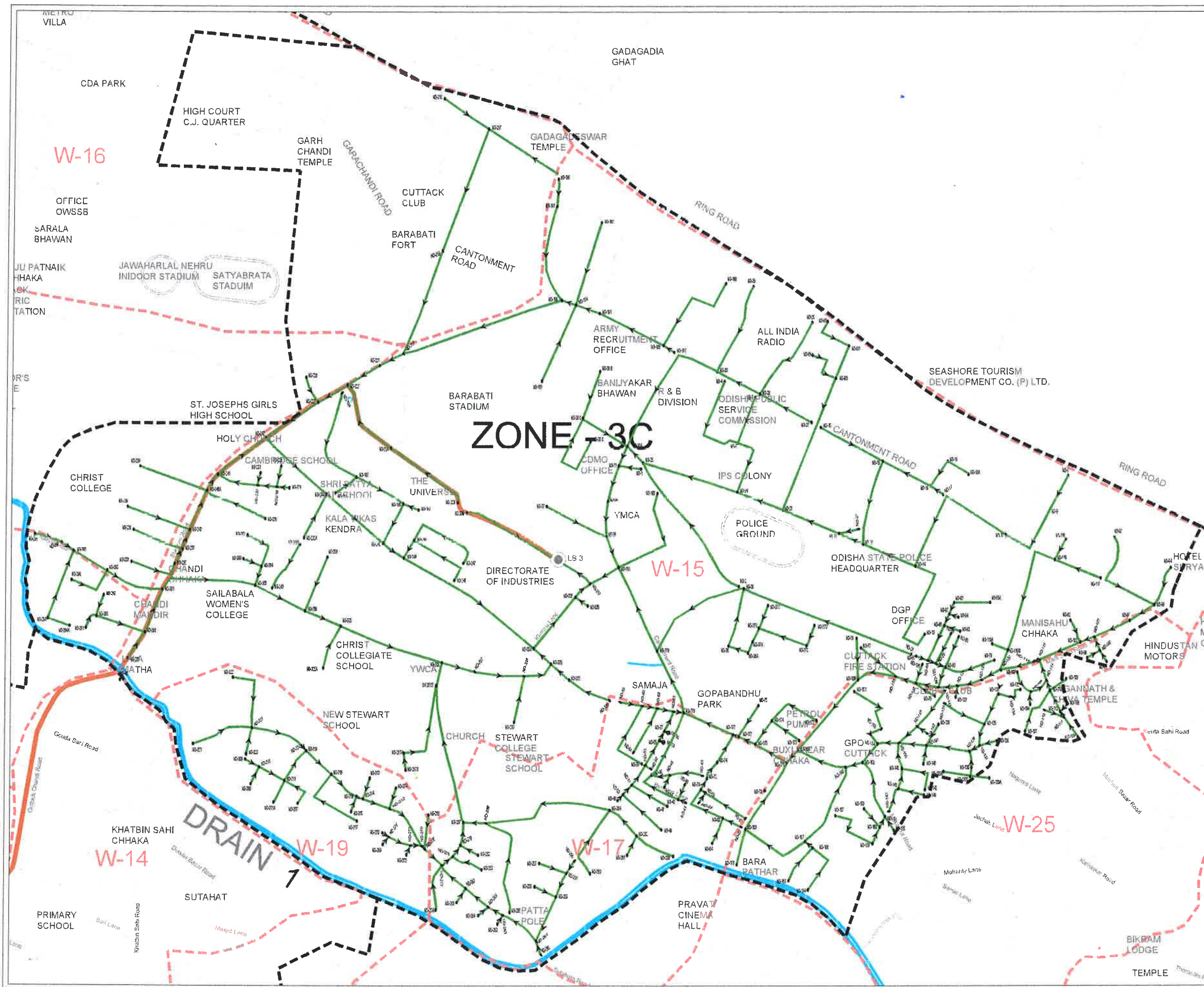

Area of Zone - 3C = 2.18 Sqkm

TENDER DRAWING FOR HOUSE SEWER CONNECTION

LEGENDS

ROAD	
SEWER PIPE LINE	
RISING MAIN	
ZONE BOUNDARY	
WARD BOUNDARY	
WARD NOS	

Rev	Revision Description	Drawn	Date	Checked	Auth'd

Project: **JICA Assisted Odisha Integrated Sanitation Improvement Project**

Client: **ODISHA WATER SUPPLY & SEWERAGE BOARD**

Consultant: **ENGINEERING & PROJECT MANAGEMENT CONSULTANTS**
 (Consortium of Tokyo Engineering Consultants Co., Ltd., Tetra Tech Inc, and Egis bcom International)

Title: **SEWER LAYOUT ZONE-3C,CUTTACK**

Original Scale	Drawn	Checked	Authorised	S.MAZZ
NTS	Date: 05/04/2012	Date:	Date:	A2
Drawing Number	Ref. Scale	Sheet No.	Rev	
TD/HSC/Z-SC/08	0:0:0	08/012-c-c-s	0	

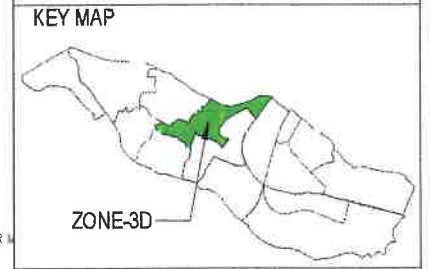
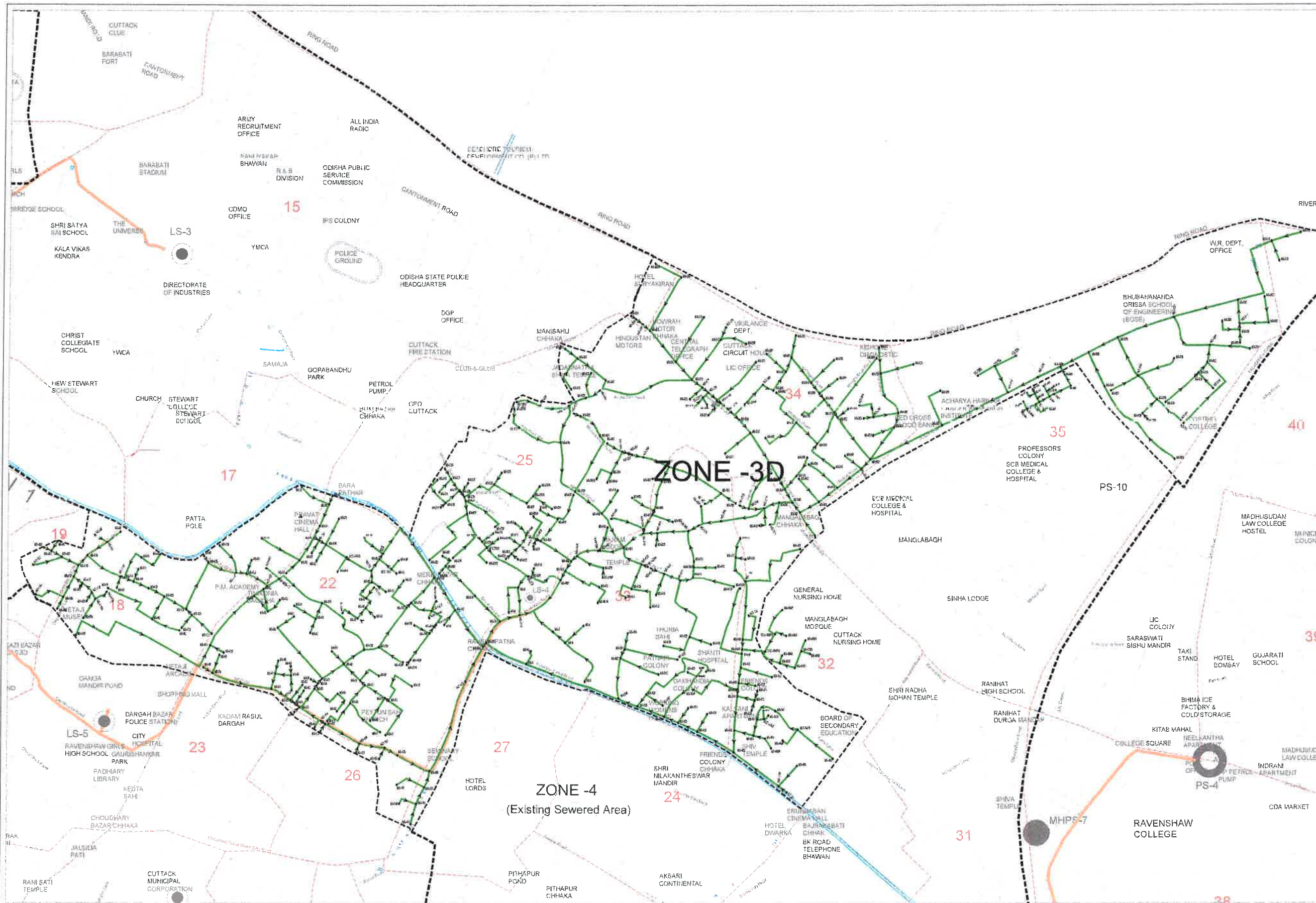

Area of Zone - 3D = 2.11 Sqkm

TENDER DRAWING FOR HOUSE SEWER CONNECTION

- LEGENDS**
- ROAD
 - SEWER PIPE LINE
 - RIISING MAIN
 - ZONE BOUNDARY
 - WARD BOUNDARY
 - WARD NOS

Rev	Revision Description	Drawn	Date	Check	Auth'd

Project
JICA Assisted Odisha Integrated Sanitation Improvement Project

Client
ODISHA WATER SUPPLY & SEWERAGE BOARD

Consultant
ENGINEERING & PROJECT MANAGEMENT CONSULTANTS
 (Consortium of Tokyo Engineering Consultants Co. Ltd., Tetra Tech Inc. and Egis becom International)

Plot No. - 10-02/1585, Sector-10, CDA, Bhubaneswar - 751013, Odisha
 Phone : 0674 - 6863333
 ODSIBA, Fax : 0674-6603311

Plot No. - 10-02/1585, Sector-10, CDA, Bhubaneswar, Odisha
 Phone : 0674 - 2309804
 Fax : 0674 - 2309805

Title
SEWER LAYOUT ZONE-3D, CUTTACK

Original Scale	Drawn	Checked	Authorised	S.SIZE
NTS	Date 05/04/2022	Date	Date	A2
Drawing Number	Ref. Code	Sheet No	Rev	
TD/HSC/Z-3D/07	OBMP/02 - C - D		0	

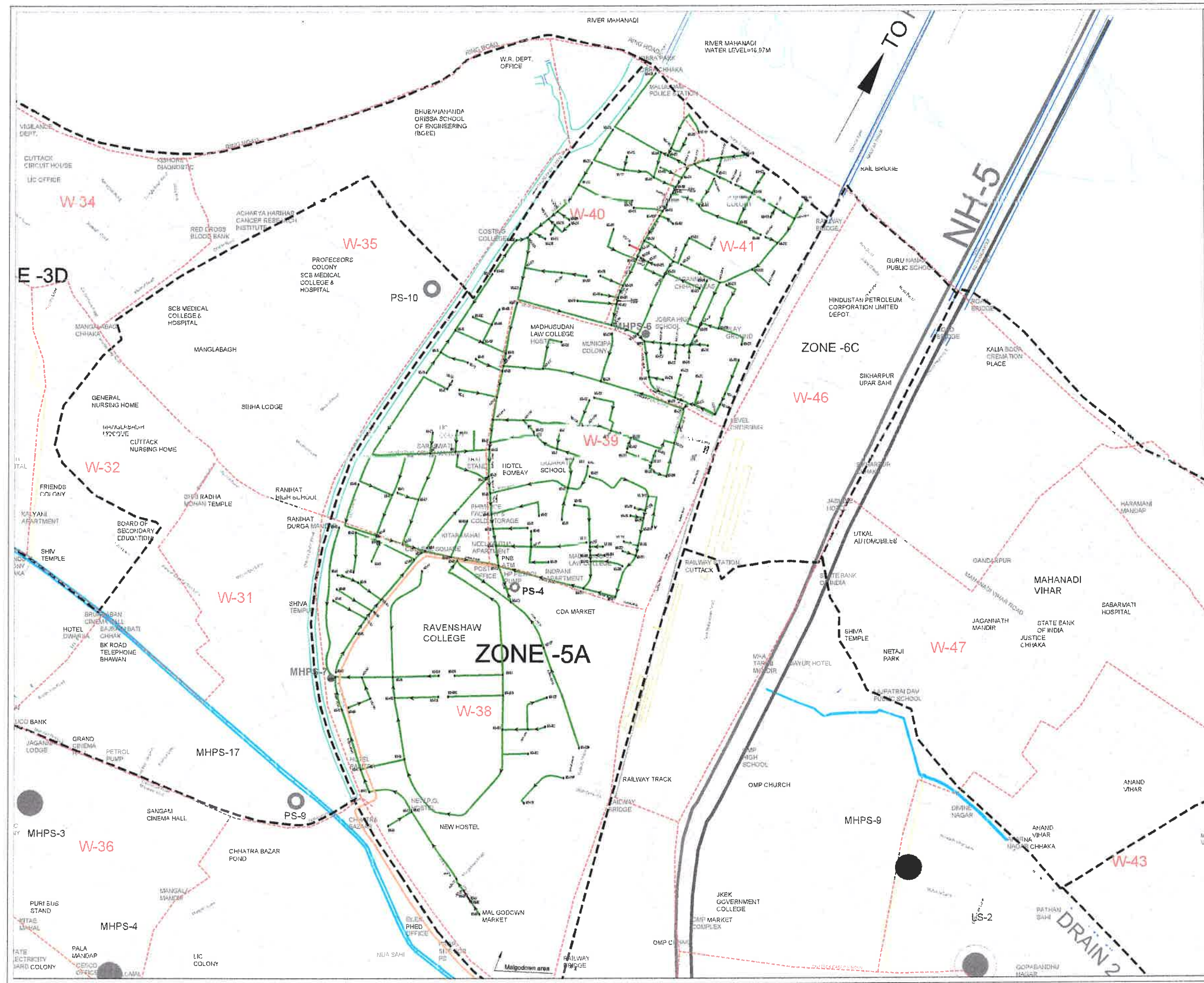

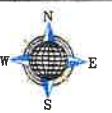

KEY MAP



ZONE-5A

Area of Zone - 5A = 1.94 Sqkm

TFNDR DRAWING FOR HOUSE SEWER CONNECTION

LEGENDS

ROAD	
SEWER PIPE LINE	
RISING MAIN	
ZONE BOUNDARY	
WARD BOUNDARY	
WARD NOS	

Rev	Revision Description	Drawn	Date	Checked	Authd

Project

JICA Assisted Odisha Integrated Sanitation Improvement Project



ODISHA WATER SUPPLY & SEWERAGE BOARD

Consultant

ENGINEERING & PROJECT MANAGEMENT CONSULTANTS

Tetra Tech Inc. and Egli beam International

Plot No. - E-61, Indira, Patia
 Bhubaneswar - 751013, Odisha
 Phone : 0674 - 660323
 ODISHA, Fax : 0674-660311

Plot No. - 2(C)78, Sector-8, Near Justice Jugal Kishore Park, CDA, Cuttack - 753014, Odisha
 Phone : 0671 - 226922
 Phone : 0671 - 226922

SEWER LAYOUT ZONE-5A, CUTTACK

Original Scale	Drawn	Checked	Authd	Scale
NTS	Date 05/04/22	Date	Date	A2

Drawing Number	Ref. Code	Sheet No.	Rev
TDH/CZ-5A/08	DISP62 - C - D		0

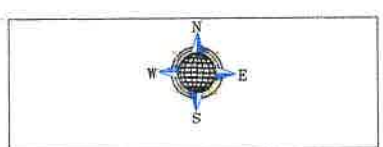
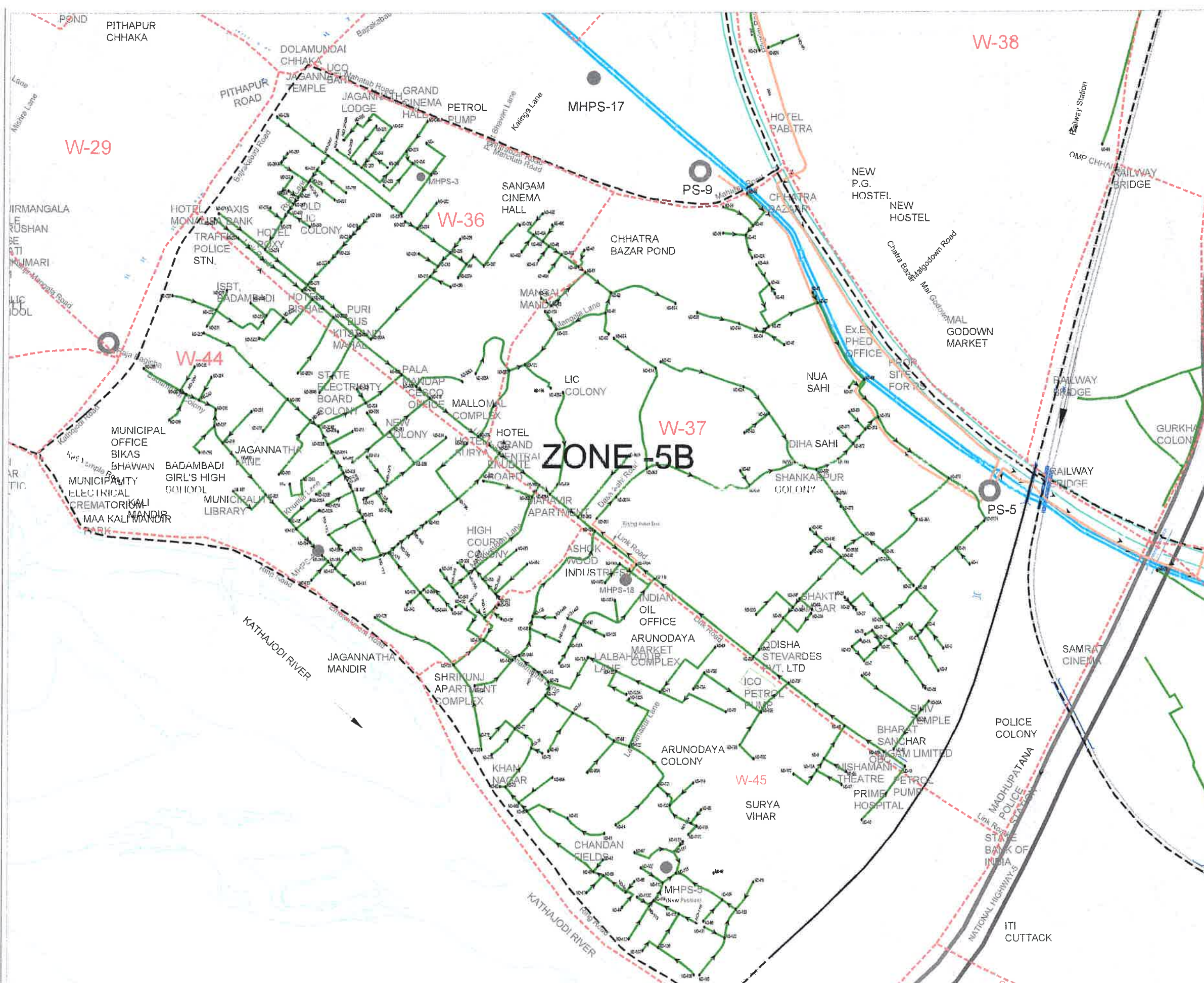

Area of Zone - 5B = 2.22 Sqkm

TENDER DRAWING FOR HOUSE SEWER CONNECTION

LEGENDS

ROAD	
SEWER PIPE LINE	
RISING MAIN	
ZONE BOUNDARY	
WARD BOUNDARY	
WARD NOS	W-16

Rev	Revision Description	Drawn	Date	Checked	Authd

Project: **JICA Assisted Odisha Integrated Sanitation Improvement Project**

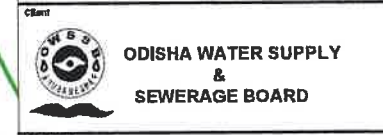

Consultant: **ENGINEERING & PROJECT MANAGEMENT CONSULTANTS**

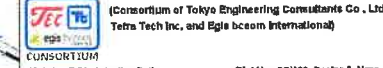

Plot No - 651, Indradya, Para Bhubaneswar - 751015, Odisha
 Phone : 0674 - 6963392
 OMRWA, Fax : 0674-6623111

Title: **SEWER LAYOUT ZONE-5B, CUTTACK**

Original Scale	Drawn	Checked	Authorised	S.SIZE
NTS	Date 05/04/2022	Date	Date	A2
Drawing Number	Rev. Code	Sheet No	Rev	
TD/HSCZ-5B/09	OMP/R2 - C - D		0	

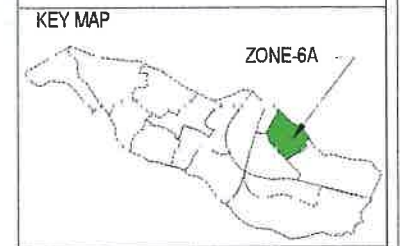
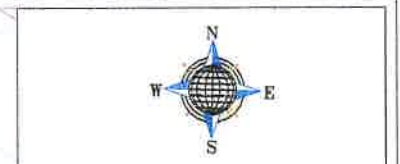
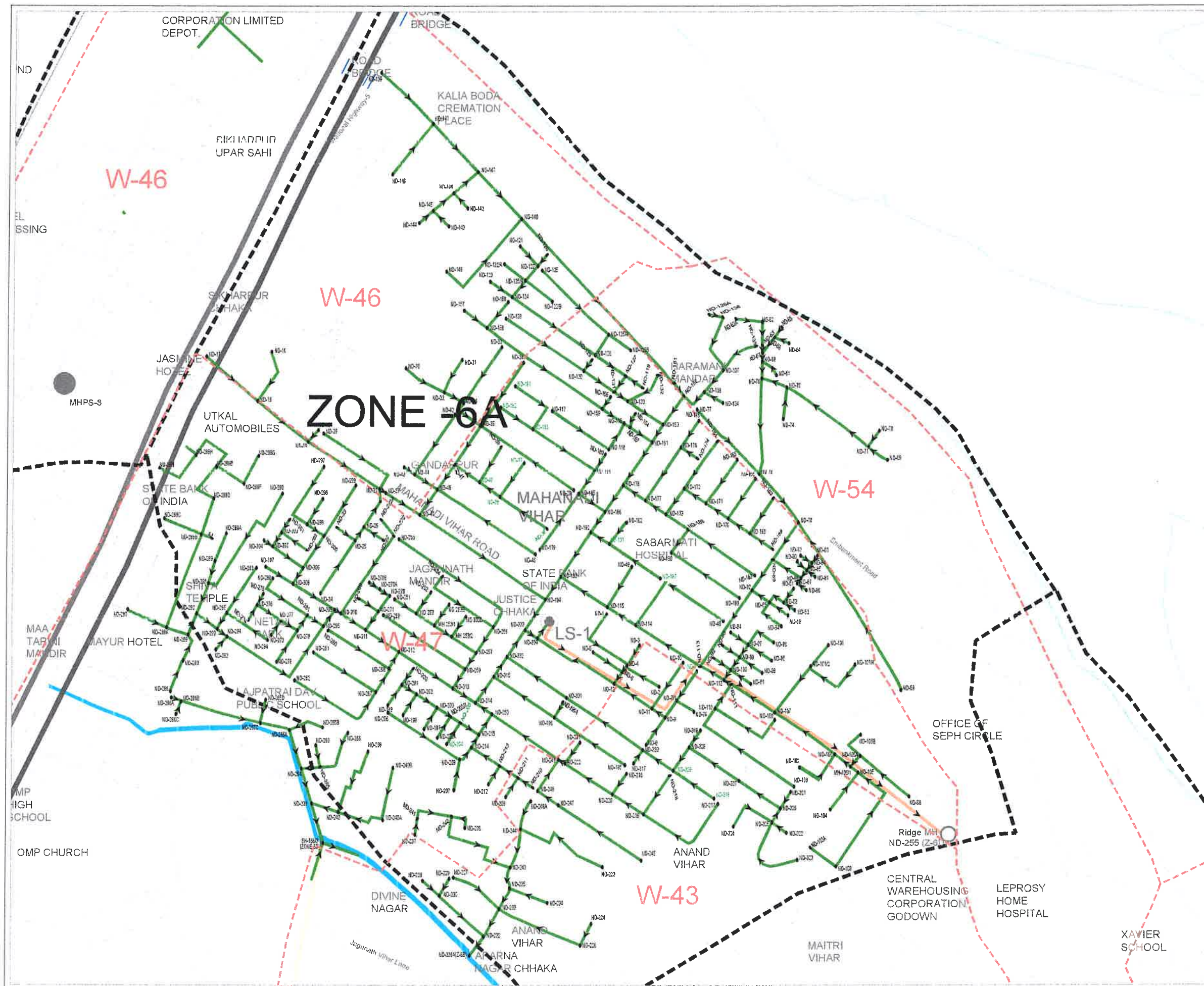

Area of Zone - 6A = 1.39 Sqkm

TENDER DRAWING FOR HOUSE SEWER CONNECTION

LEGENDS

- ROAD
- SEWER PIPE LINE
- RISING MAIN
- 70M ROUNDBURY
- WARD BOUNDARY
- WARD NOS W-16

Rev	Revision Description	Drawn	Date	Checked	Authd

Project: **JICA Assisted Odisha Integrated Sanitation Improvement Project**

Client: **ODISHA WATER SUPPLY & SEWERAGE BOARD**

Consultant: **ENGINEERING & PROJECT MANAGEMENT CONSULTANTS**
 (Consortium of Tokyo Engineering Consultants Co., Ltd. Tetra Tech Inc. and Egis hceem International)

Title: **SEWER LAYOUT ZONE-6A, CUTTACK**

Original Scale	Drawn	Checked	Authorised	6.50E
NTS	Date: 05/04/2012	Date:	Date:	A2
Drawing Number	Ref. Code	Sheet No	Rev	
TD/HSC/Z-6A/10	DMR/2 - C - D		0	

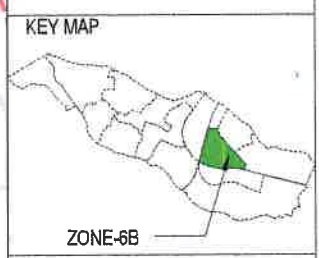
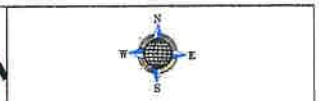
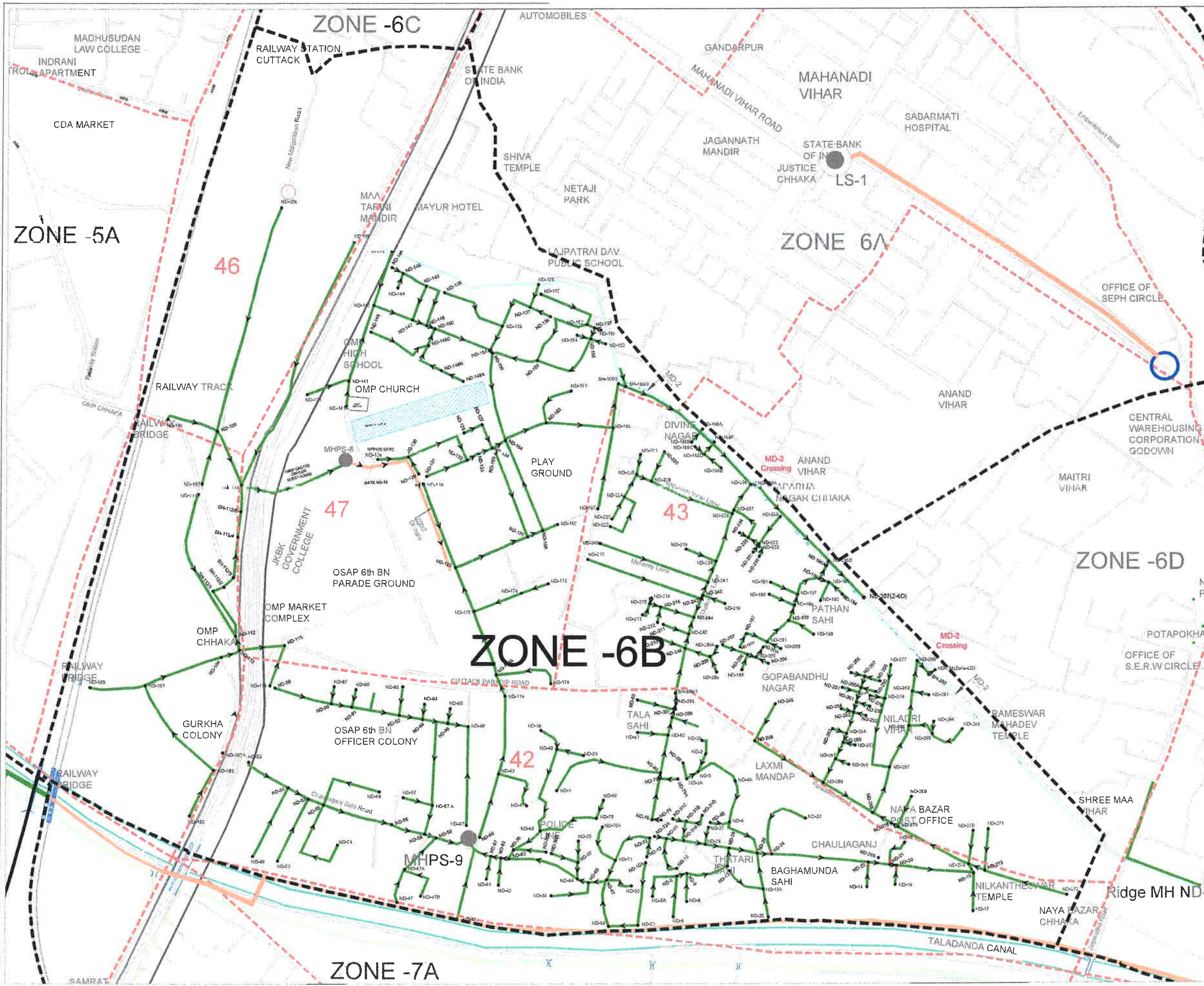

Area of Zone - 6B = 1.76 Sqkm

TENDER DRAWING FOR HOUSE SEWER CONNECTION

LEGENDS

ROAD	
SEWER PIPE LINE	
RISING MAIN	
ZONE BOUNDARY	
WARD BOUNDARY	
WARD NOS	W-16

Rev	Description	Date	Checked	Author

Project: JICA Assisted Odisha Integrated Sanitation Improvement Project

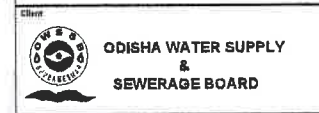

Consultant: ENGINEERING & PROJECT MANAGEMENT CONSULTANTS

(Consortium of Tokyo Engineering Consultants Co., Ltd. Tatra Tech Inc. and Egis Inco International)

SEWER LAYOUT ZONE-6B, CUTTACK

Original Scale	Drawn	Checked	Authorised	SHEET
NTS	Dir	Dir	Dir	A2
Drawing Number	Rev. Code	Scale	Sheet No.	Rev
TB/MC/Z-6B/11	OMP01-C-D			0

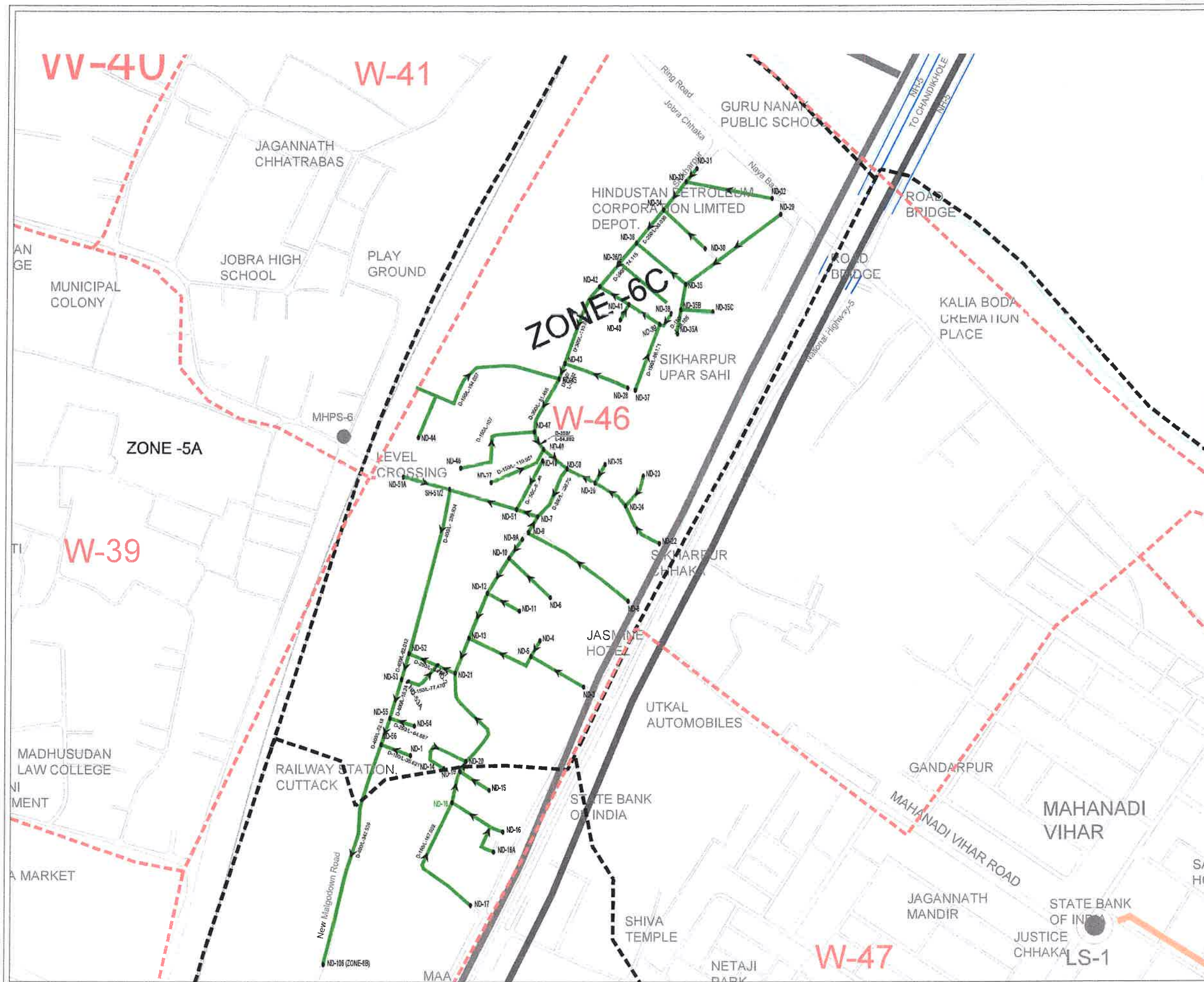

KEY MAP

ZONE-6C

Area of Zone - 6C = 0.41 Sqkm

TENDER DRAWING FOR
HOUSE SEWER CONNECTION

LEGENDS

ROAD	
SEWER PIPE LINE	
RISING MAIN	
ZONE BOUNDARY	
WARD BOUNDARY	
WARD NOS	W-16

Rev	Revision Description	Drawn	Date	Checked	Auth'd

Project

**JICA Assisted
Odisha Integrated Sanitation
Improvement Project**

Client

**ODISHA WATER SUPPLY
&
SEWERAGE BOARD**

Consultant

ENGINEERING & PROJECT MANAGEMENT CONSULTANTS

(Consortium of Tokyo Engineering Consultants Co. Ltd.
Tetra Tech Inc. and Egis Incom International)

Plot No. - 10-42/1584, Sector-10,
CDA, Markhaganar,
Bhubaneswar - 751013, Odisha
Phone : 0674-4603333
ODSMB, Fax : 0674-4603311

Title

SEWER LAYOUT ZONE-6C, CUTTACK

Original Scale	Drawn	Checked	Authorised	S. No.
NTS	Date: 02/04/2022	Date:	Date:	A2

Crawing Number	Ref. Code	Sheet No.	Rev
TD/HC/Z-6C/12	OSMP/12 - C - D		0

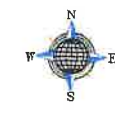
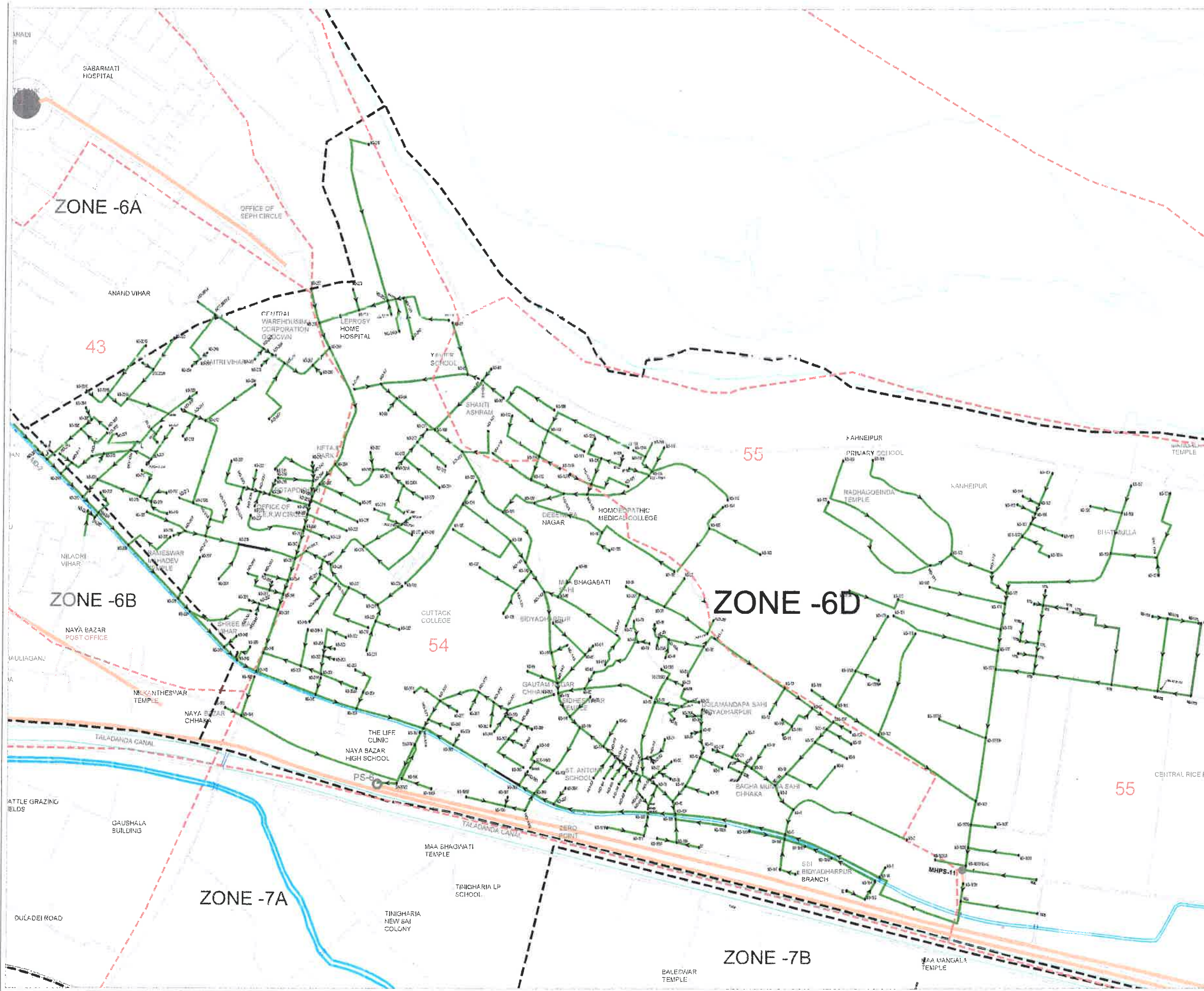

KEY MAP

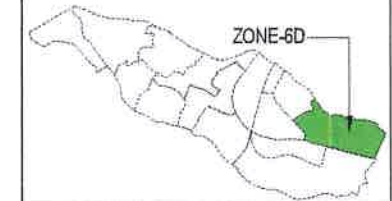

Area of Zone - 6D = 3.29 Sqkm

TENDER DRAWING FOR HOUSE SEWER CONNECTION

LEGENDS

- ROAD
- SEWER PIPE LINE
- RISING MAIN
- ZONE BOUNDARY
- WARD BOUNDARY
- WARD NOS W-16

Rev	Revision Description	Drawn	Date	Checked	Approved

Project **JICA Assisted Odisha Integrated Sanitation Improvement Project**

Client **ODISHA WATER SUPPLY & SEWERAGE BOARD**

Consultant **ENGINEERING & PROJECT MANAGEMENT CONSULTANTS**

(Consortium of Tokyo Engineering Consultants Co., Ltd. Tetra Tech Inc. and Egis Incoem International)

Plot No. - 55, Indusky, Palla, Cuttack - 751012, Odisha
 Phone : 9876 - 988323
 Odisha, Fax : 9876-988324

Plot No. - 2C/118, Sector-8, Near Justice Jagan Nath Park, CDA, Cuttack - 751014, Odisha
 Phone : 9876 - 988323
 Odisha, Fax : 9876-988324

SEWER LAYOUT ZONE-6D, CUTTACK

Original Scale	Drawn	Checked	Author	Sheet	Scale
NTS	Date: 05/04/2022	Date:	Date:	Sheet 01	A2
Drawing Number	08PP/02 - C - D	Ref. Com	Sheet No	Rev	0

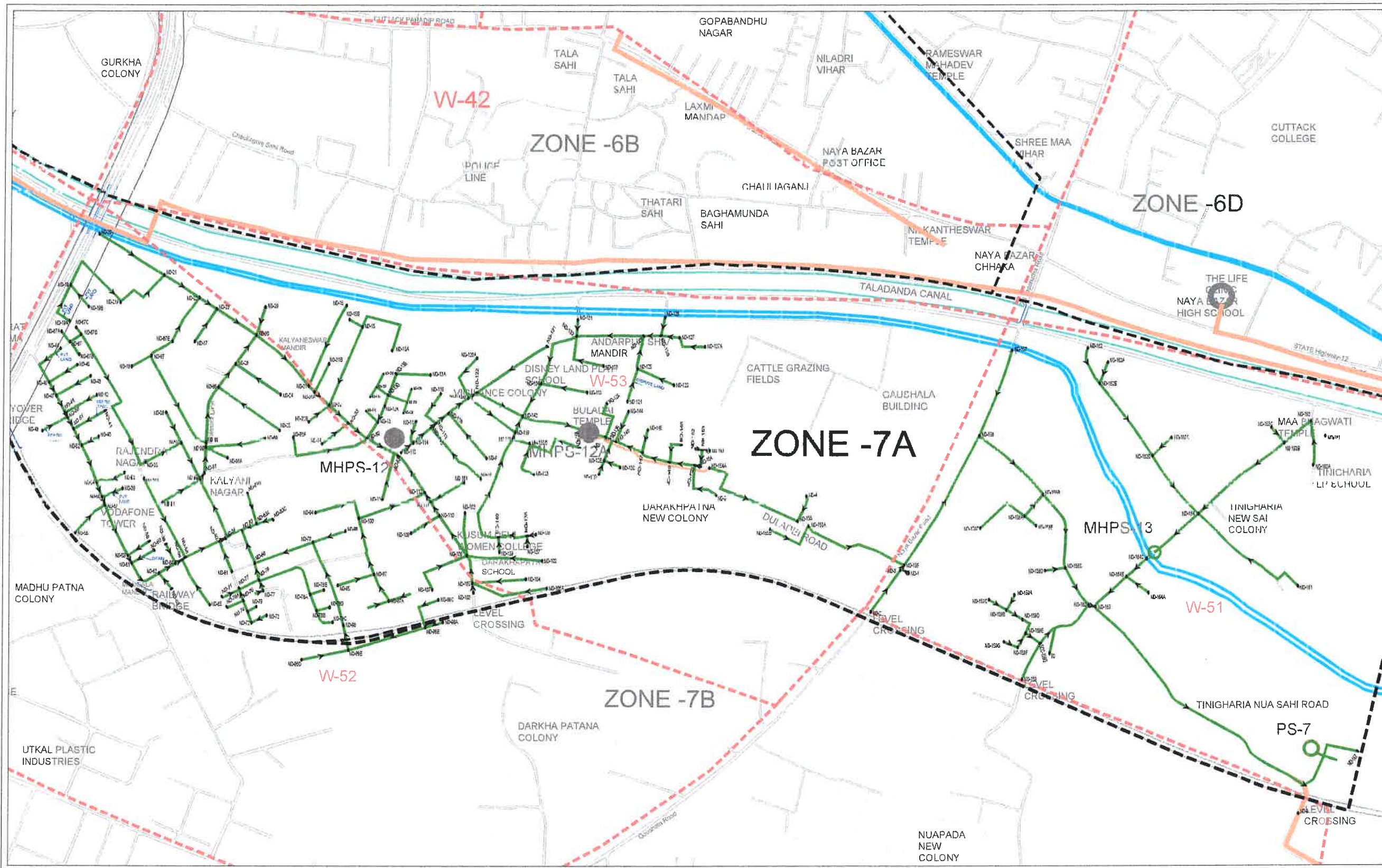



KEY MAP



ZONE-7A

Area of Zone - 7A = 1.59 Sqkm

TENDER DRAWING FOR HOUSE SEWER CONNECTION

LEGENDS

ROAD	
SEWER PIPE LINE	
RISING MAIN	
ZONE BOUNDARY	
WARD BOUNDARY	
WARD NOS	W 16

Rev	Revision Description	Drawn	Date	Checked	Auth'd

Project

**JICA Assisted
Odisha Integrated Sanitation
Improvement Project**

Client

**ODISHA WATER SUPPLY
&
SEWERAGE BOARD**

Consultant

ENGINEERING & PROJECT MANAGEMENT CONSULTANTS

(Consortium of Tokyo Engineering Consultants Co., Ltd
Tetra Tech Inc. and Egis Incem International)

Plot No. - E-51, Infocity, Patia
Bhubaneswar - 751012, Odisha
Phone : 0674 - 6822203
ODISHA, Pin : 6674-6603211

Plot No. - 3C/188, Sector-8, Near
Jawahar Jugal Kishore Park, CDA,
Cuttack - 753 014, Odisha
Phone : 0671 256892

Title

SEWER LAYOUT ZONE-7A,CUTTACK

Original Scale	Drawn	Checked	Authorised	S.SIZE
NTS	Date: 05/04/2022	Date:	Date:	A3

Drawing Number	Ref. Code	Sheet No	Rev
TD/HSCZ-7A/14	OMIP02 - C - D	0	0

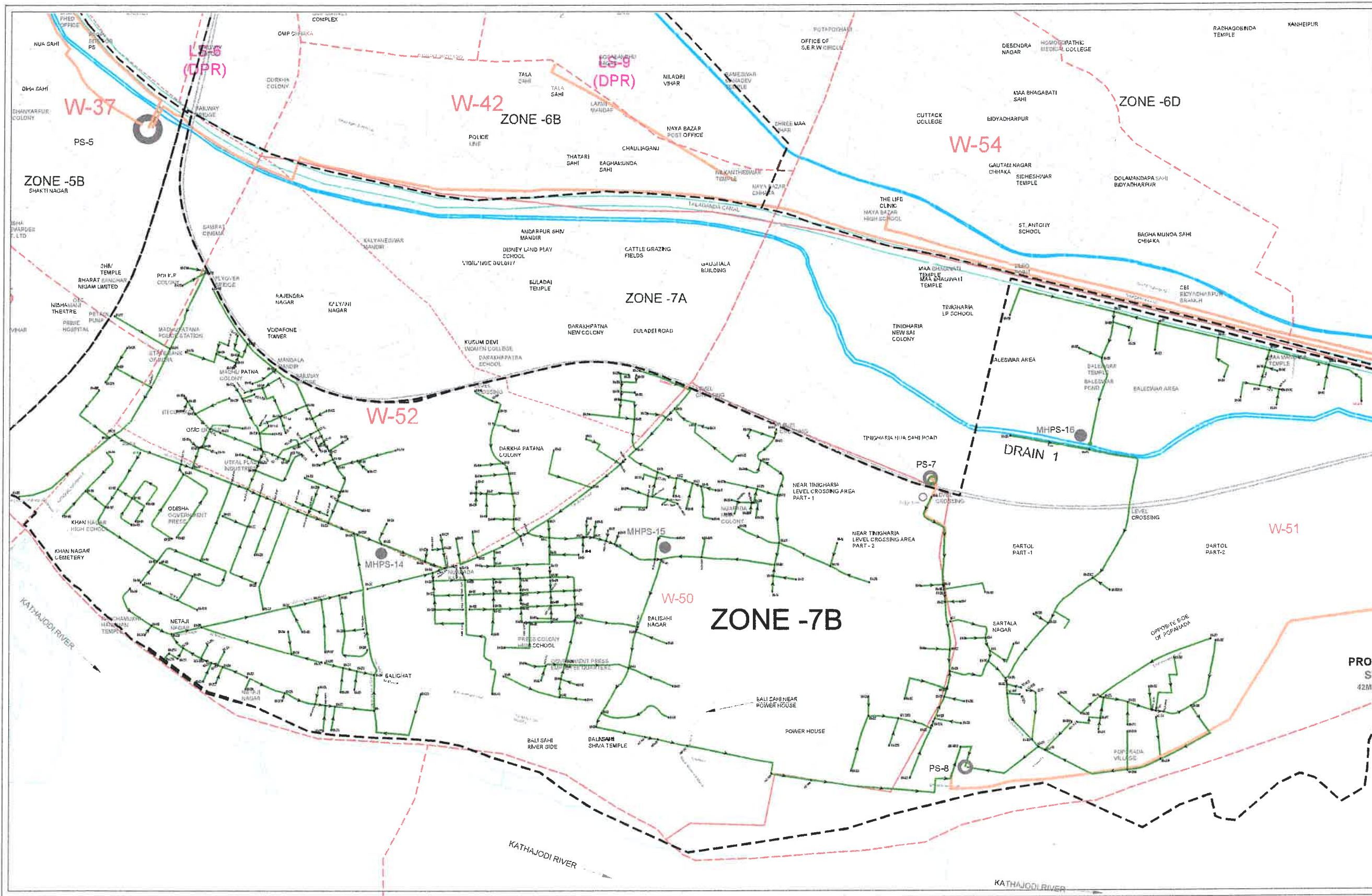



KEY MAP







ZONE-7B

Area of Zone - 7B = 5.70 Sqkm

TENDER DRAWING FOR HOUSE SEWER CONNECTION

LEGENDS

ROAD	
SEWER PIPE LINE	
RISING MAIN	
ZONE BOUNDARY	
WARD BOUNDARY	
WARD NOS	W-16

Rev	Revision Description	Drawn	Date	Check'd	Auth'd

**JICA Assisted
Odisha Integrated Sanitation
Improvement Project**

**ODISHA WATER SUPPLY
&
SEWERAGE BOARD**

ENGINEERING & PROJECT MANAGEMENT CONSULTANTS

 <p>(Consortium of Tokyo Engineering Consultants Co., Ltd. Tetra Tech Inc. and Egis bceom International)</p>	<p>Plot No. 2C/189, Sector-9, CDA, near Jugal Mishra park Cuttack - 753014, Odisha Phone : 0674 - 8603233 ODISHA, Fax : 0674-8603311</p>
-------------------------------------------------------------------------------------------------------------------------------------------------------------------------------------------------------	----------------------------------------------------------------------------------------------------------------------------------------------------------

SEWER LAYOUT ZONE-7B,CUTTACK

Original Scale	Drawn	Checked	Authorised	S. SIZE
NTS	Date: 05/04/2022	Date:	Date:	A3
Drawing Number	Ref. Code	Sheet No	Rev	
TDHSC/Z-7A/15	01SP/02-C-D		0	

ANNEXURE – IV

Format of Joint Measurement Record (JMR)

Construction for the House Connections to the Sewerage System, Cuttack

Joint Measurement Record (JMR) for Package-....., Zone-.....

Location		From Node	To Node	MEASUREMENTS OF ITEMS					Remarks
S. No.	House No.	L/R Side	Name of Consumer	Item- A	Item- B	Item- C	Item- D	Item- E	
				Road Cutting/Restoration	Laying of PVC Pipe	Making Connection with existing SCC/IC	Drain Crossing	Construction of Chamber Inside Property Boundary	
				(m)	(m)	Nos.	Nos.	Nos.	
1		L-1							
2		L-2							
3		L-3							
4		R-1							
5		R-2							

Note: JMR shall be signed after completion of all the house connections from Node to Node.

For Contractor

For PMC

For OWSSB

Signature & Date

Signature & Date

Signature & Date